

West Burton Solar Project

Environmental Statement Appendix 4.1: Engineering Drawings and Sections

Prepared by: Island Green Power, Omnia Power, and JSM
March 2023

PINS reference: EN010132
Document reference: APP/WB6.3.4.1
APFP Regulation 5(2)(o)



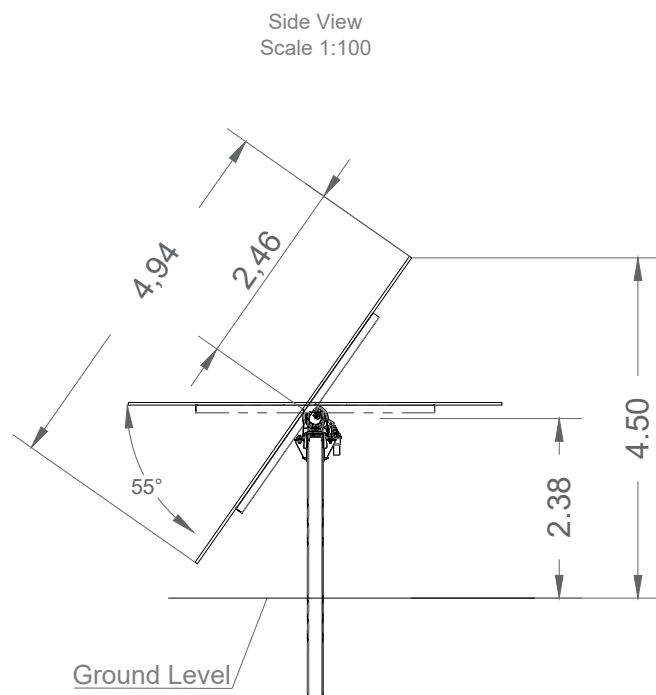
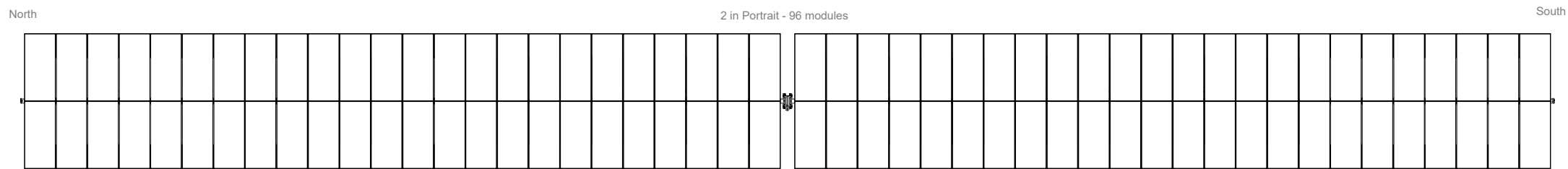
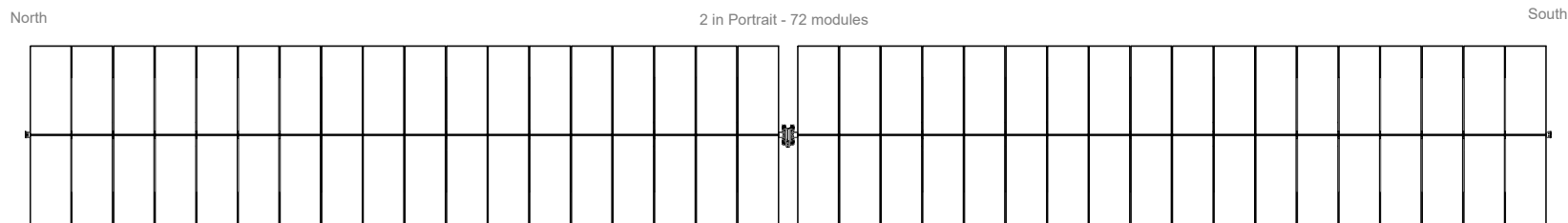
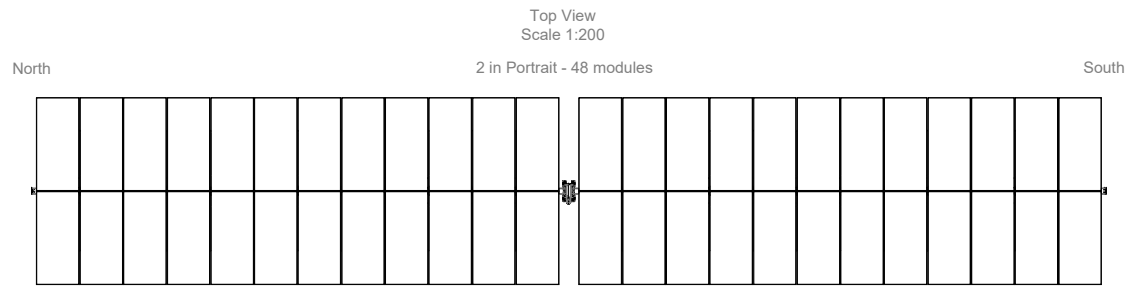
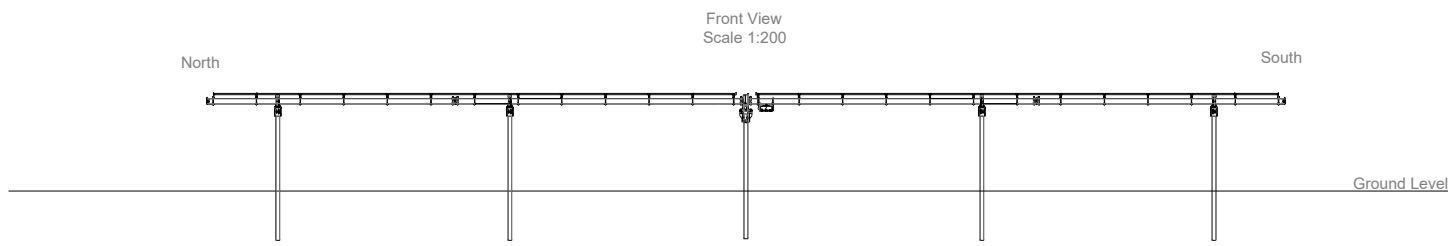

Module: JA Solar 625W
1134mm x 2465mm x 35mm

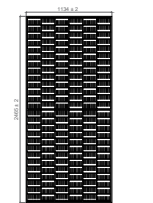

General Legend:

Project:	West Burton Solar Project		
Project Location:	Land near Gainsborough, Lincolnshire, United Kingdom		
Ownership:	West Burton Solar Project Limited		
Document Title:	Mounting Structure Details - Trackers Side, Front and Top Views		
Sheet format:	A3 "420 x 297"	Scale:	Varies
Document amendments:	v.1 10/01/2023	M.N.	
Company:	GREEN POWER	Island Green Power UK Limited Unit 20.2, Coda Studios 189 Munster Road, London SW6 6AW	

Top View
Scale 1:100
2 in Portrait - 48 modules

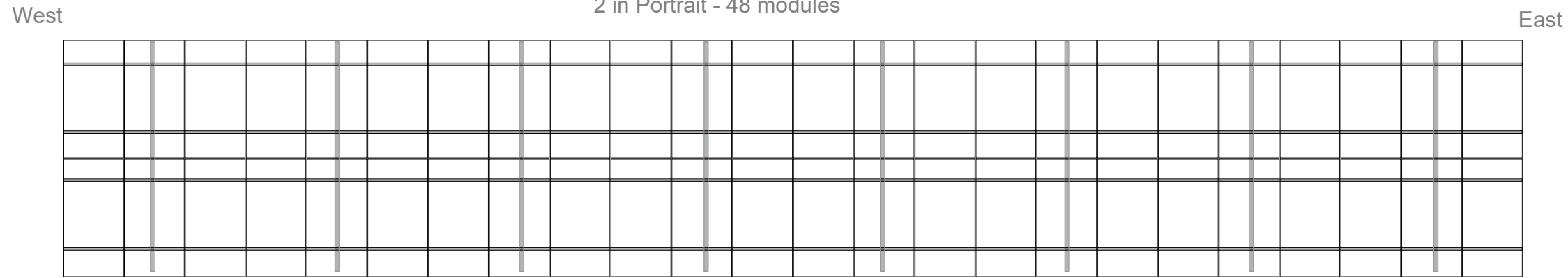

Top View
Scale 1:100
2 in Portrait - 24 modules

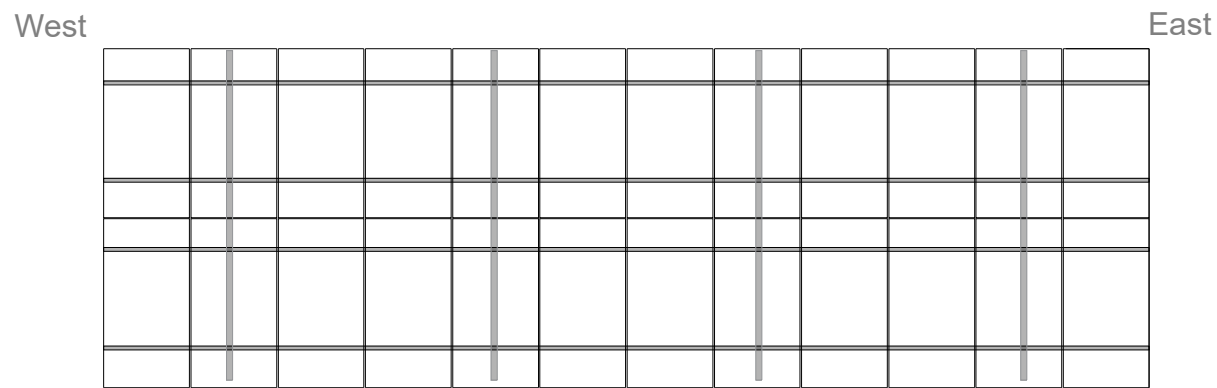

Side View
Scale 1:50

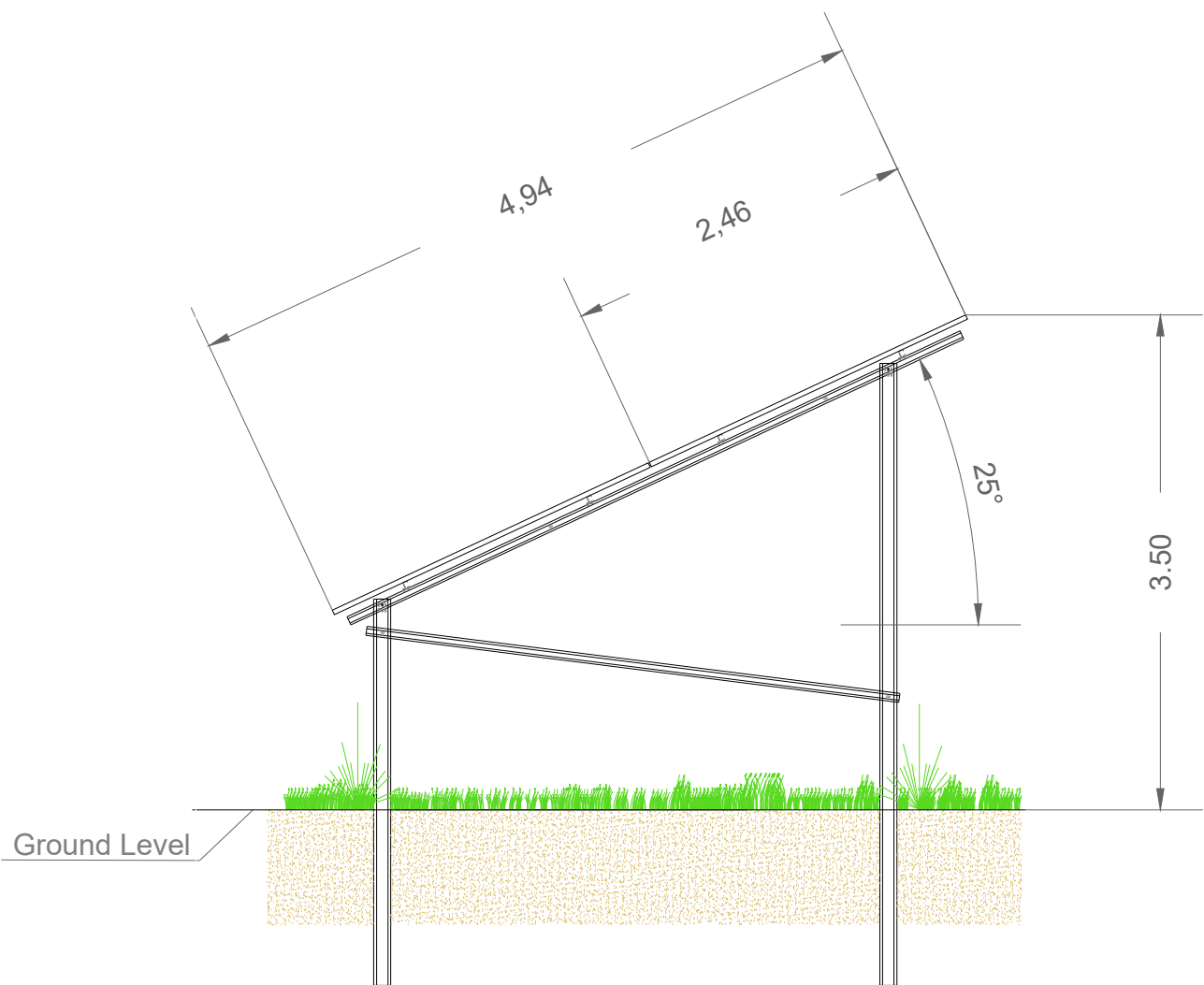

Front View
Scale 1:100

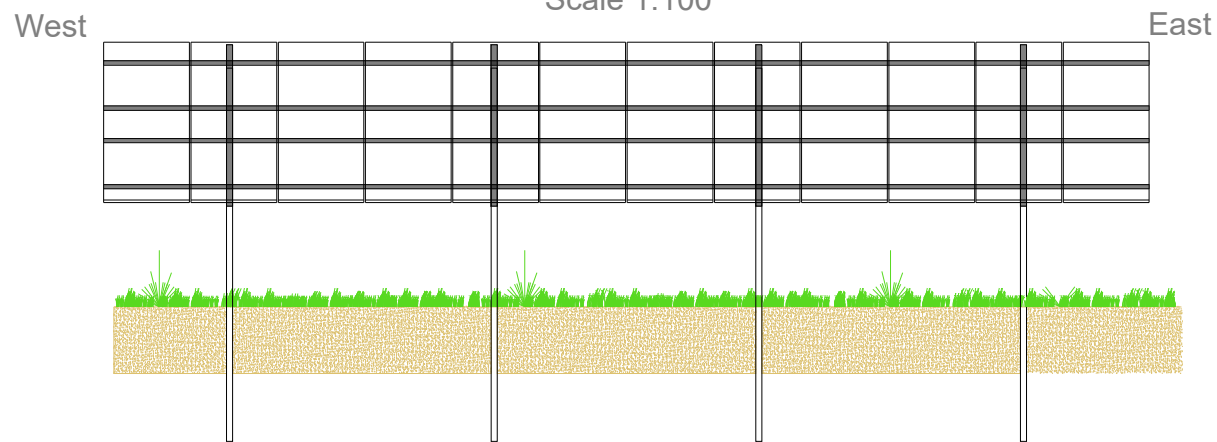

General Legend:

General Legend:	

Project:	West Burton Solar Project	
Project Location:	Land near Gainsborough, Lincolnshire, United Kingdom	
Ownership:	West Burton Solar Project Limited	
Document Title:	Mounting Structure Details - Fixed - Piles Side, Front and Top Views	
Sheet Format:	A3 "420 x 297"	Scale: Varies
Document amendments:	v.1 14/02/2023 J.M.N.	Comments:
Company:	 Island Green Power UK Limited Unit 20.2, Coda Studios 189 Munster Road, London SW6 6AW	

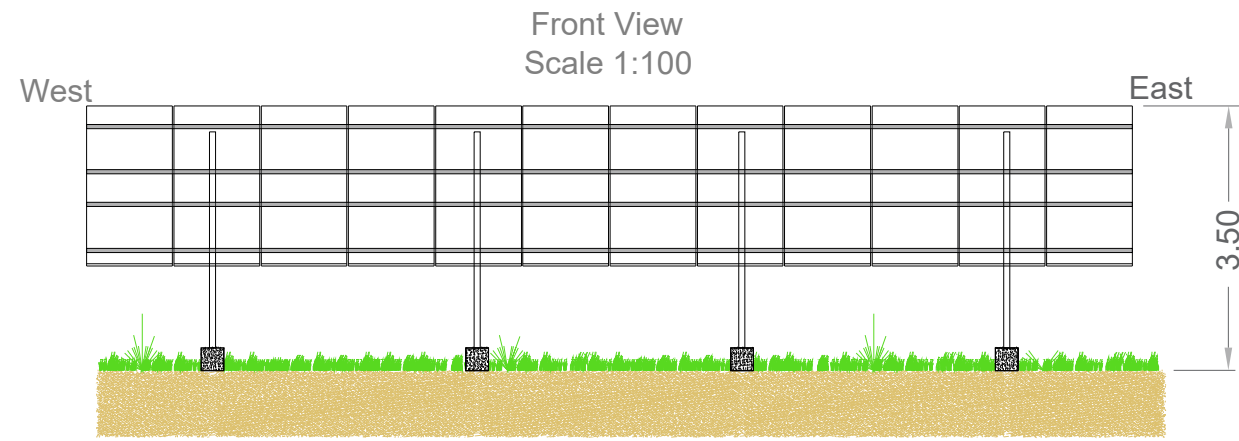
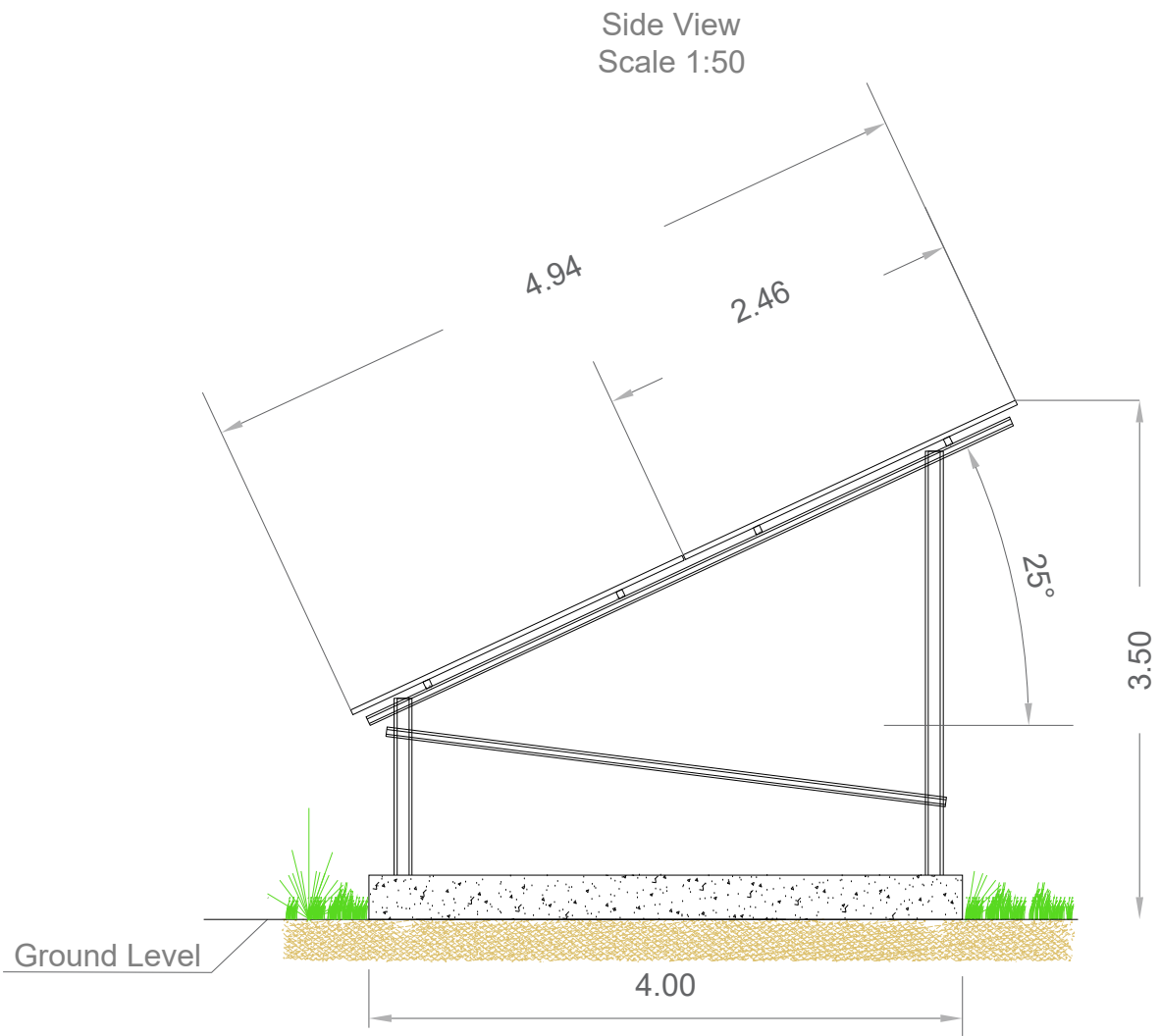
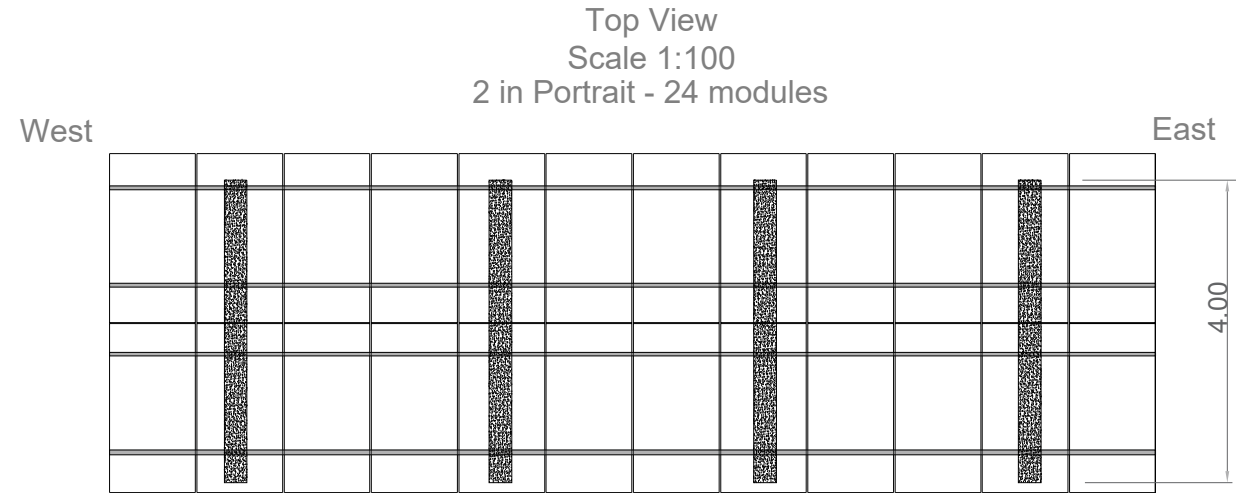
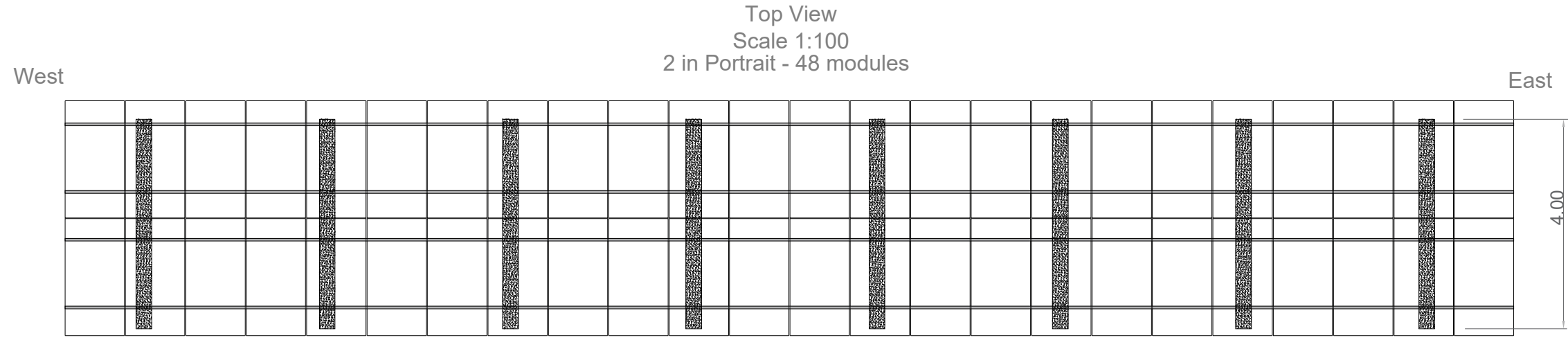

General Legend:

General Legend:	

Project: West Burton Solar Project

Project Location: Land near Gainsborough, Lincolnshire, United Kingdom

Ownership: West Burton Solar Project Limited

Document Title: Mounting Structure Details - Fixed Concrete Feet Side, Front and Top Views

Sheet Format: A3 *420 x 297" **Scale:** Varies

Document: v.1 10/01/2023 M.N. **Comments:**

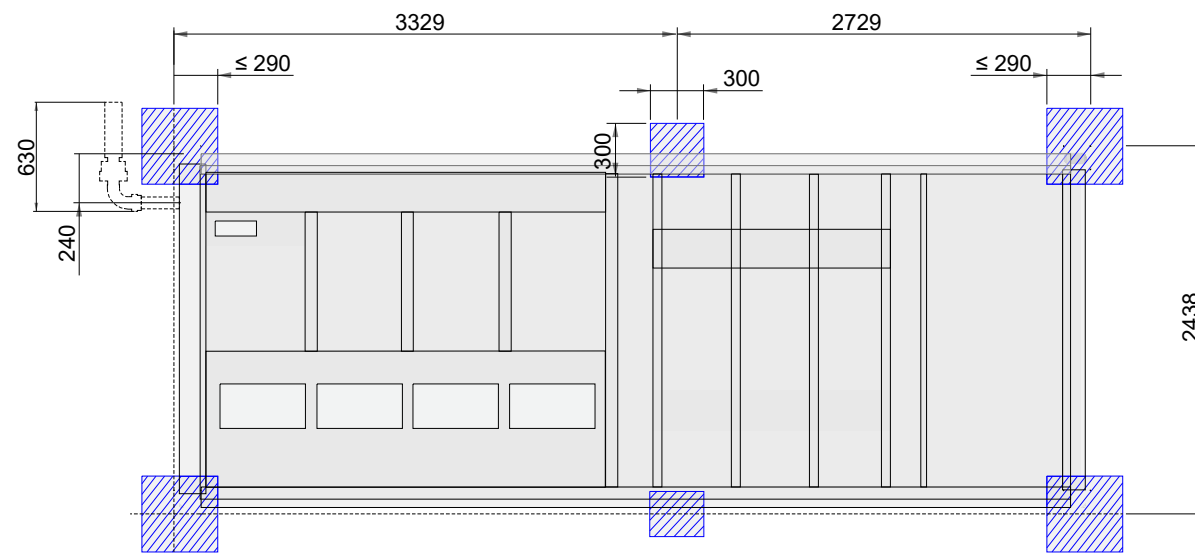
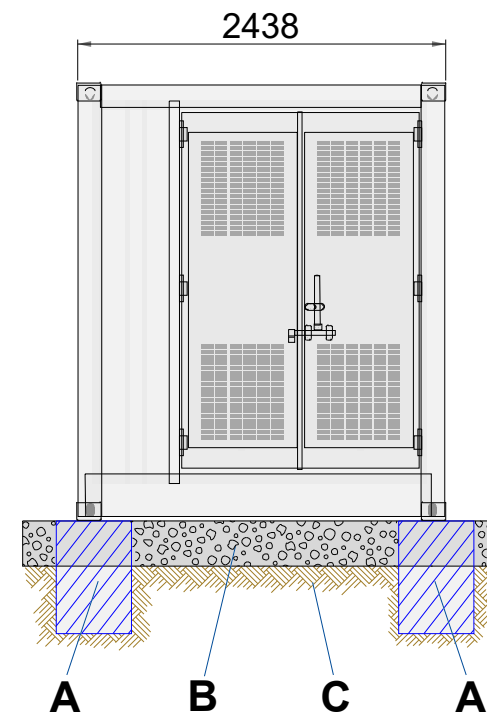
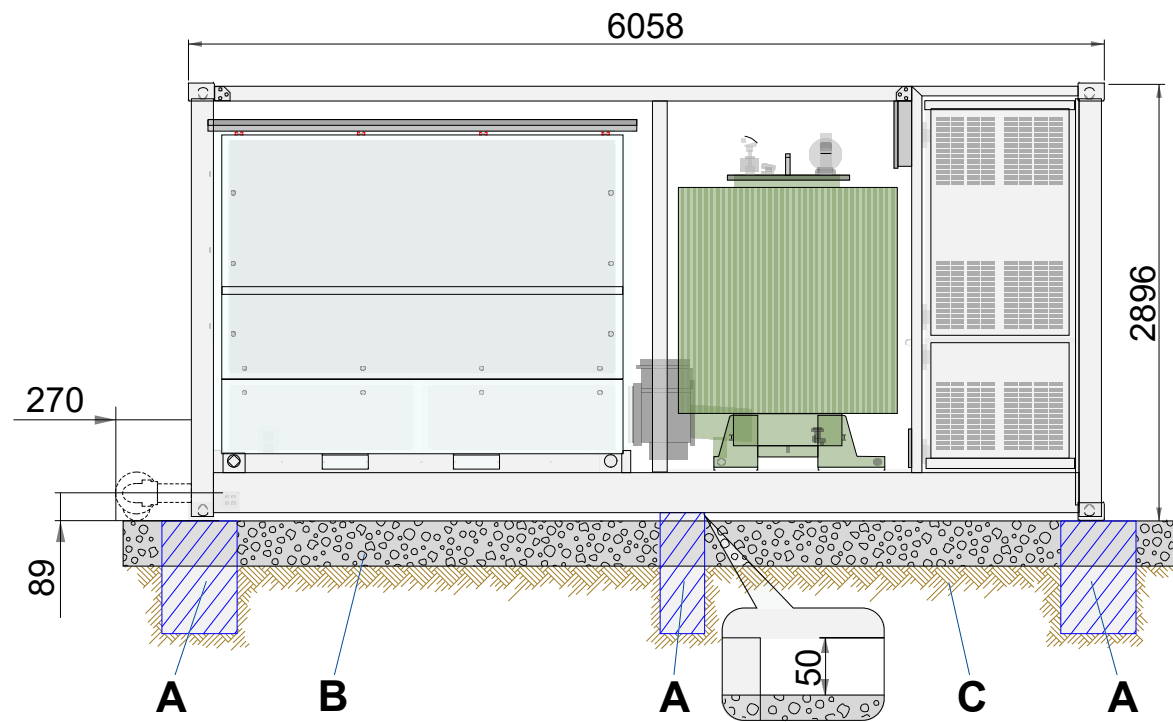

General Legend:

A	Support Point Foundation
B	Pea Gravel Ground
C	Solid Ground, e.g. Gravel



Project: West Burton Solar Project

Project Location: Land near Gainsborough, Lincolnshire, United Kingdom

Ownership: West Burton Solar Project Limited

Document Title: Solar PV Conversion Unit

Sheet format: A3 420 x 297" Scale: 1:50

Document amendments	Rev.	Date	M.N.	Comments
	v.1	13/01/2023	M.N.	
	v.2	14/02/2023	M.N.	

Company: Island GREEN POWER
 Island Green Power UK Limited
 Unit 20.2, Coda Studios
 189 Munster Road, London SW6 6AW

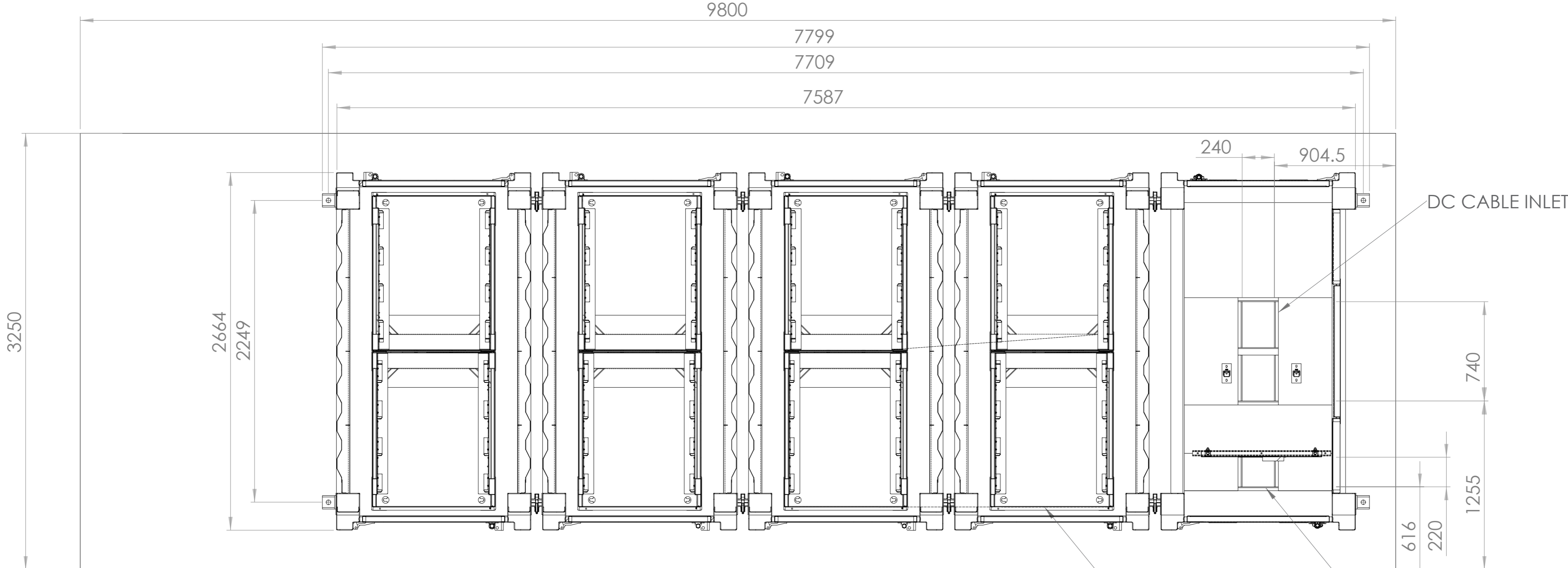

SECTION A-A

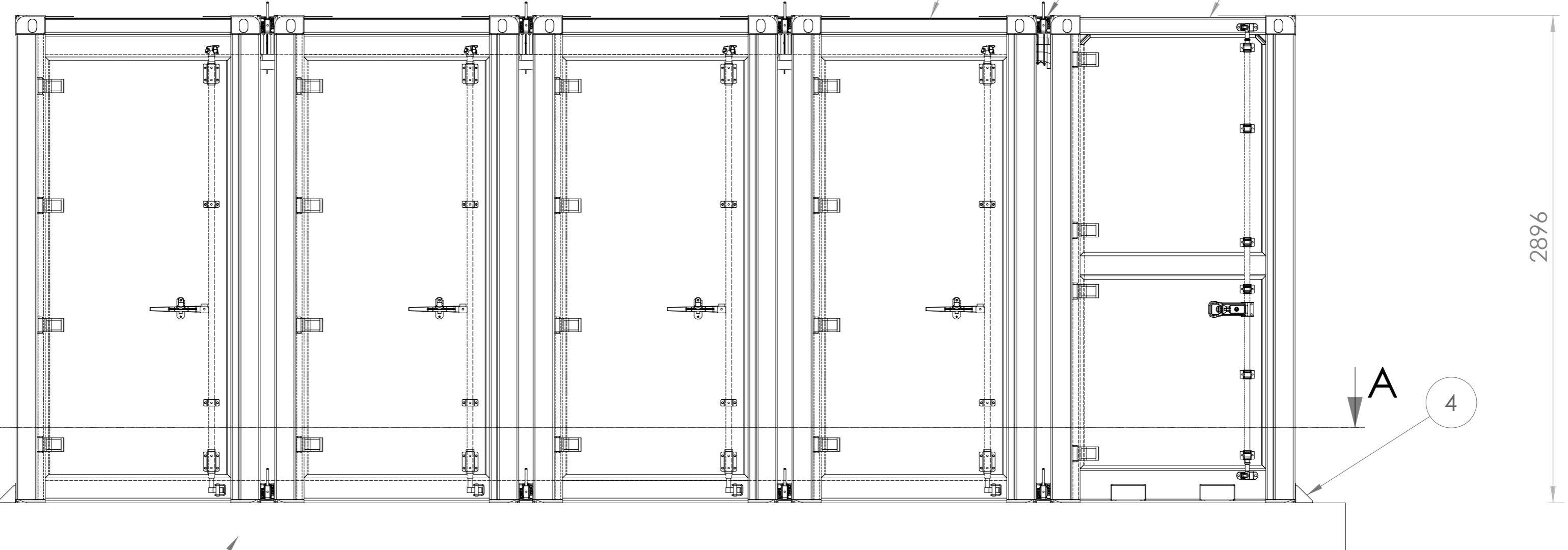
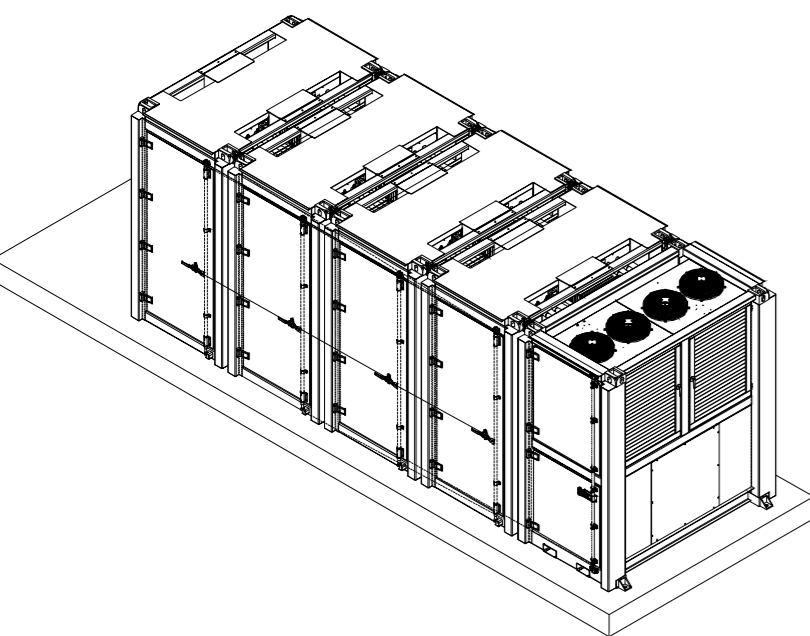

FOUNDATION THICKNESS TO BE DETERMINED FROM GROUND STUDY AT THE SITE.

General Legend:

Pos.	Description	Qty
1	COMBI BLOCK	1
2	BATTERY BLOCK	4
3	INTERCONNECT HOSE - COMBI TO BATT	4
4	INTERCONNECT HOSE - BATT TO BATT	12
16	INTERCONNECT HARNESS - TERMINATING	1
20	FOUNDATION	1



Project:	West Burton Solar Project		
Project Location:	Land near Gainsborough, Lincolnshire, United Kingdom		
Ownership:	West Burton Solar Project Limited		
Document Title:	Battery Side View and A-A Section		
Sheet format:	A2 "594 x 420"	Scale:	1:30
Document amendments:	v.1	05/01/2023	M.N.
Company:	Island GREEN POWER	Island Green Power UK Limited	Unit 20.2, Coda Studios 189 Munster Road, London SW6 6AW

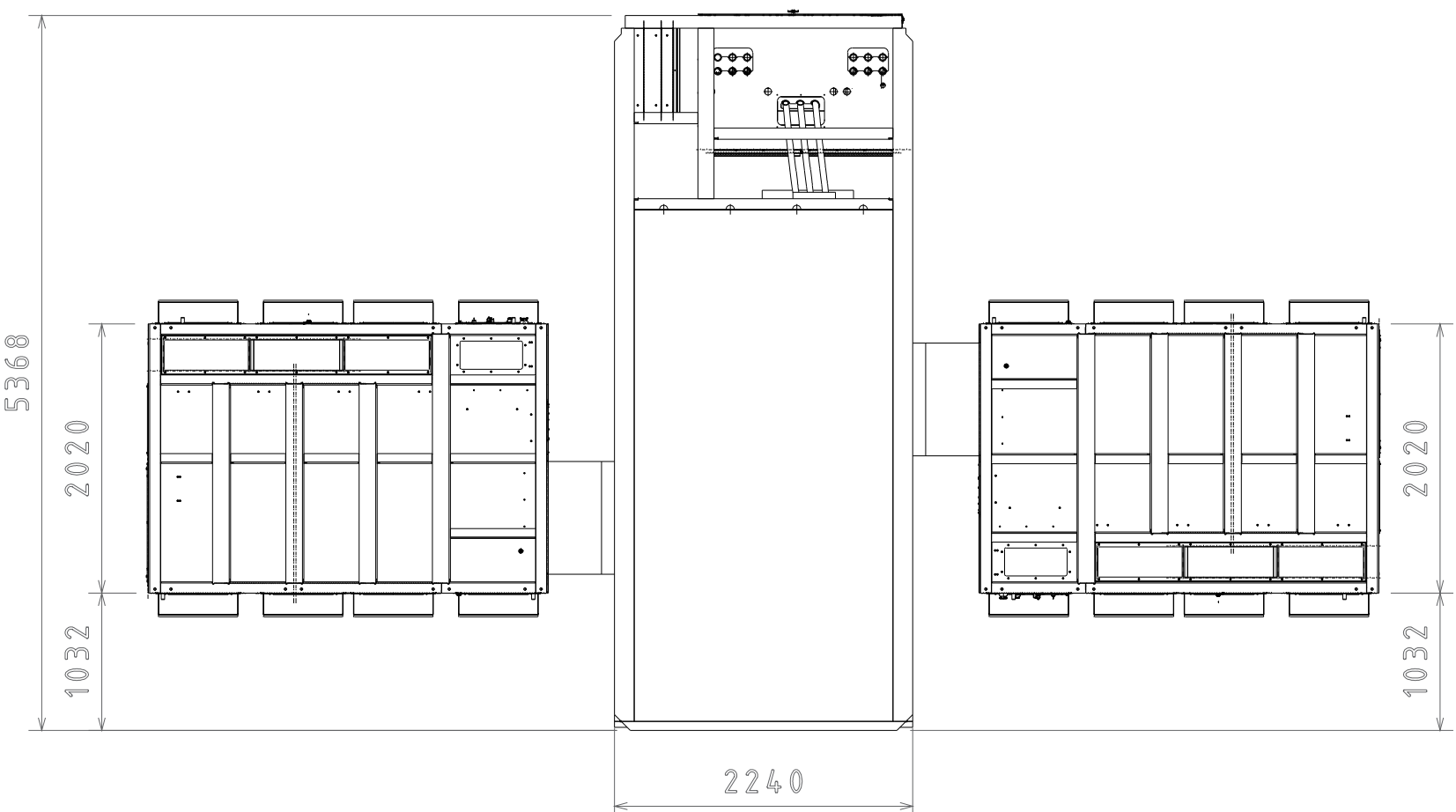

BOTTOM VIEW

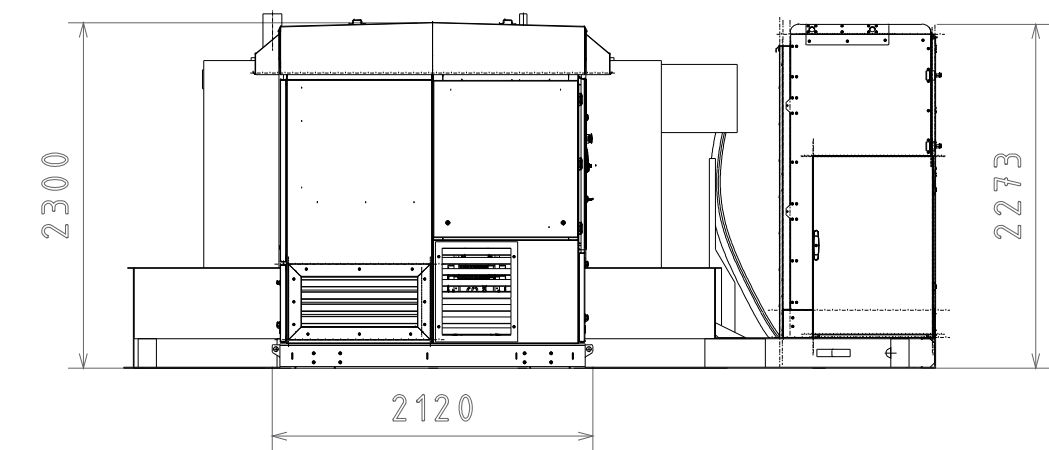

LEFT VIEW

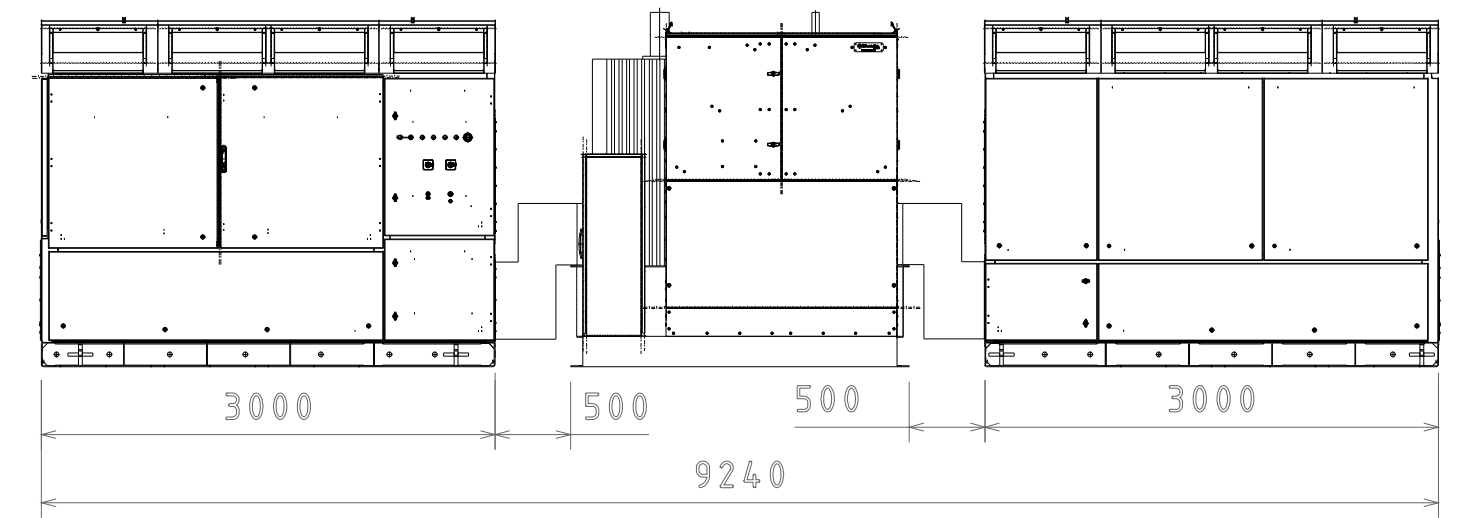

FRONT VIEW

General Legend:



Project:	West Burton Solar Project												
Project Location:	Land near Gainsborough, Lincolnshire, United Kingdom												
Ownership:	West Burton Solar Project Limited												
Document Title:	Battery Storage Conversion Unit												
Sheet Format:	A3 420 x 297												
Scale:	1:1000												
Document Revisions:	<table border="1"> <tr> <th>Rev.</th> <th>Date</th> <th>By</th> <th>Comments</th> </tr> <tr> <td>v.1</td> <td>05/01/2021</td> <td>M.N.</td> <td></td> </tr> <tr> <td>v.2</td> <td>14/02/2021</td> <td>M.N.</td> <td></td> </tr> </table>	Rev.	Date	By	Comments	v.1	05/01/2021	M.N.		v.2	14/02/2021	M.N.	
Rev.	Date	By	Comments										
v.1	05/01/2021	M.N.											
v.2	14/02/2021	M.N.											
Company:	 Island Green Power UK Limited Unit 20.2, Coda Studios 189 Munster Road, London SW6 6AW												

Dibujado por/Drawn by: D.ESPLUGUES	Titulo/Title: MV TWIN SKID COMPACT GEN3+ HEMK GEN3	Fecha/Date:	15/10/2021
Revisado por/Checked by: E.MAS		Tolerancia general según norma/General tolerance according to standar: ISO 2768-mK 	
Aprobado por/Approved by: JM.VIDAL			
Peso/Weight (kg):			-

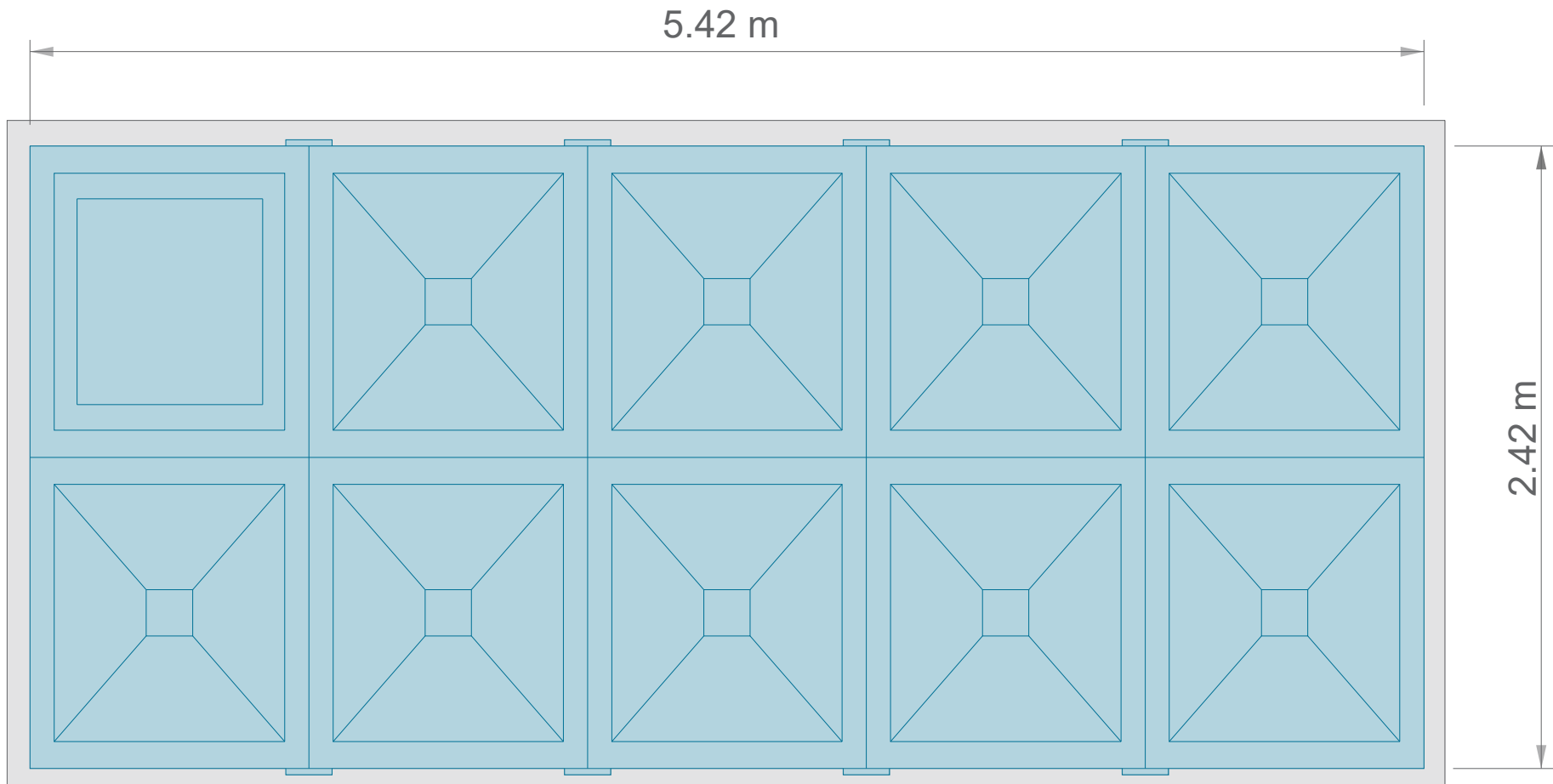

Top View

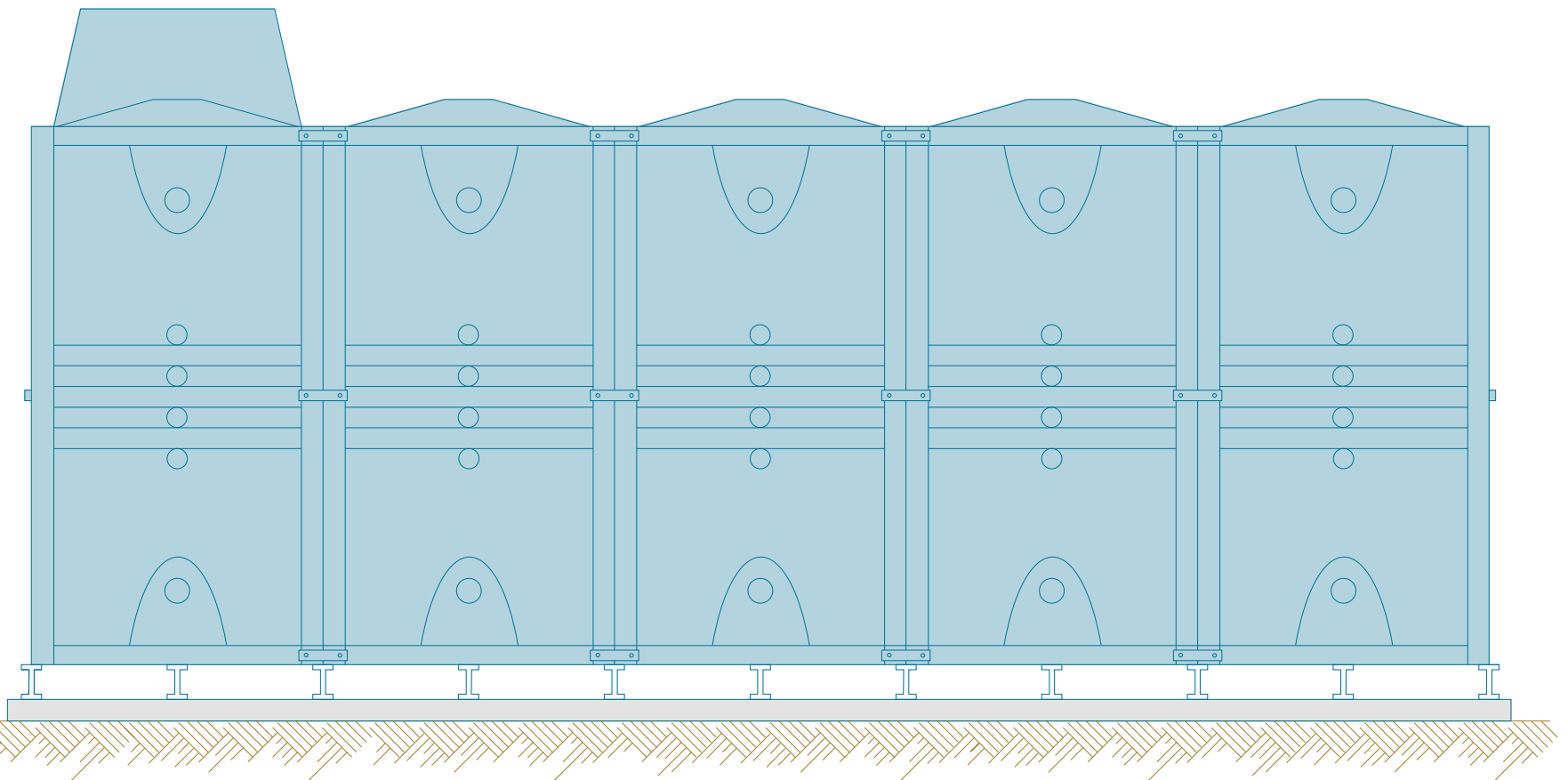

Side View

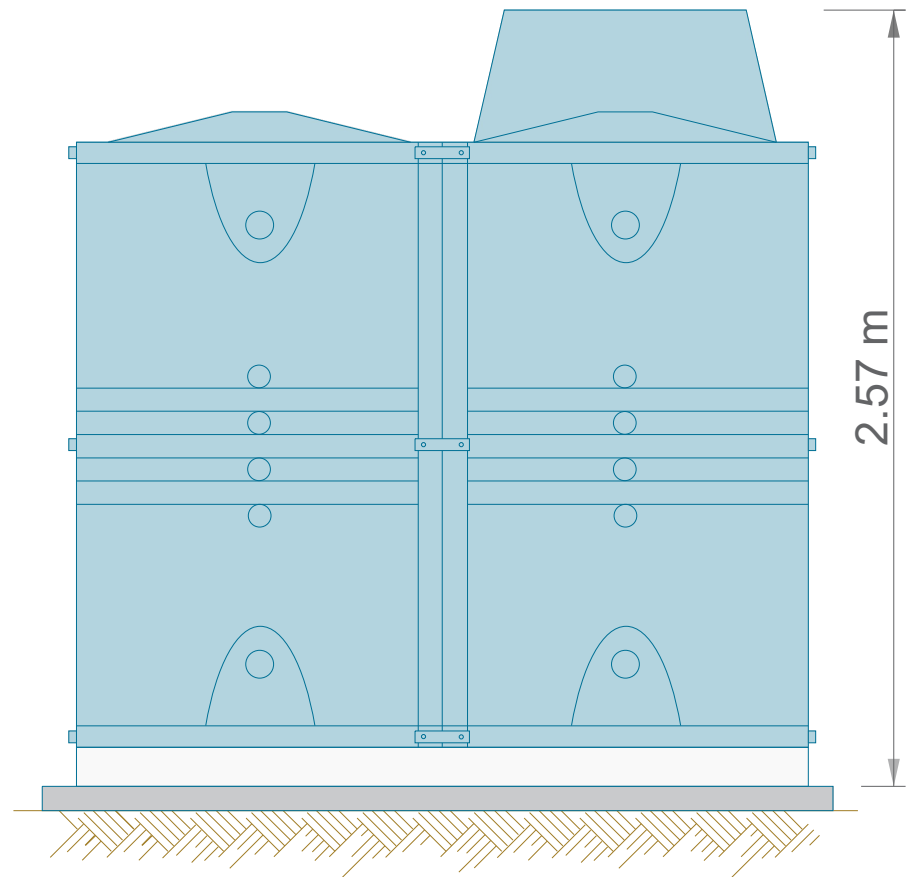

Front View

2.57 m

General Legend:

Symbol	Description

Project:	West Burton Solar Project		
Project Location:	Land near Gainsborough, Lincolnshire, United Kingdom		
Ownership:	West Burton Solar Project Limited		
Document Title:	Water Tanks		
Sheet format:	A3 "420 x 297"	Scale:	1:25
Document versions:	v.1	11/01/2023	M.N.
Comments:			
Company:	Island Green Power UK Limited Unit 20.2, Cods Studios 189 Munster Road, London SW6 6AW		

132kV MINIMUM ELECTRICAL CLEARANCES	
DESCRIPTION	DISTANCE (m)
PHASE TO PHASE CLEARANCE	1.4
PHASE TO EARTH CLEARANCE	1.1
DESIGN CLEARANCE FOR SAFETY (VERTICAL) D _{st}	3.8
DESIGN CLEARANCE FOR SAFETY (HORIZONTAL) D _{sh}	2.9
INSULATION HEIGHT (PEDESTRIAN ACCESS)	2.4
SAFETY DISTANCE	1.4
MEWP DESIGN CLEARANCE FOR SAFETY (VERTICAL) D _{s2}	5.8
MEWP DESIGN CLEARANCE FOR SAFETY (HORIZONTAL) D _{sh2}	4.9

ABBREVIATION:

AUX TX	AUXILIARY TRANSFORMER
CB	CIRCUIT BREAKER
CSE	CABLE SEALING END
CVT	CAPACITIVE VOLTAGE TRANSFORMER
D/S	DISCONNECTOR
MK	MARSHALLING KIOSK
NER	NEUTRAL EARTHING RESISTOR
PI	POST INSULATOR
SA	SURGE ARRESTER
TX	TRANSFORMER

TO BE VIEWED IN CONJUNCTION WITH ELEVATIONS DRAWING OP-PRO918-LAY022.

THE PROPOSED SUBSTATION LAYOUT IS BASED ON ASSUMPTION THAT THERE IS NO SITE RESTRICTIONS.

THE PROPOSED BUSBAR SIZE IS 90mm x 6mm Al CONDUCTOR (2000A RATING). THE BUSBAR SIZED SHALL BE CONFIRMED DURING DETAILED DESIGN.

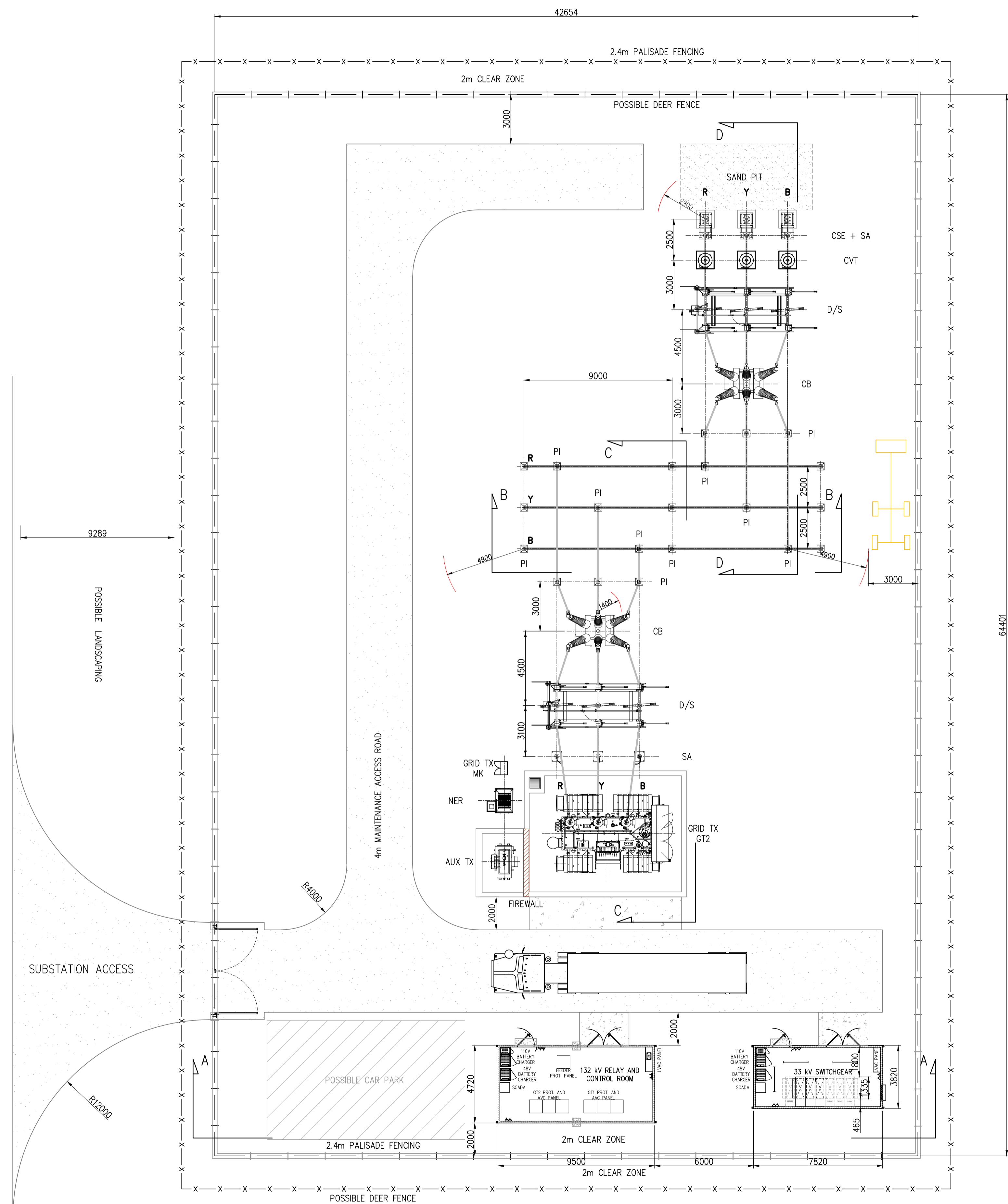

P1	11.07.22	PRELIMINARY	EC	EC	MG
----	----------	-------------	----	----	----

REV	DATE	DESCRIPTION	DRN	DES	REV & APP

Do not scale from this drawing. All dimensions given in millimeters unless otherwise stated. Copyright owned by 'Omnia Projects'.

This drawing may not be used or copied without written consent.

OMNIAProjects
 The Catalyst, York Science Park, Baird Lane, Heslington, York YO10 5GA
 email: office@omniaprojects.co.uk

Island GREEN POWER WEST BURTON SOLAR PROJECT LIMITED
 www.islandgp.co.uk

WEST BURTON 1 132/33kV SUBSTATION FOR SOLAR PARK
 SUBSTATION COMPOUND

PROJECT NAME
 NATIONAL GRID WEST BURTON CONNECTION
 CUSTOMER
 ISLAND GREEN POWER

CUSTOMER DRAWING NUMBER	STATUS
****	PRELIMINARY
DRAWING NUMBER	SCALE
OP-PRO918-LAY021	1:150
SIZE	REVISION
A1	P1

PRELIMINARY
 NOT FOR SITE USE

132kV MINIMUM ELECTRICAL CLEARANCES	
DESCRIPTION	DISTANCE (m)
PHASE TO PHASE CLEARANCE	1.4
PHASE TO EARTH CLEARANCE	1.1
DESIGN CLEARANCE FOR SAFETY (VERTICAL) D _{st}	3.8
DESIGN CLEARANCE FOR SAFETY (HORIZONTAL) D _{sh}	2.9
INSULATION HEIGHT (PEDESTRIAN ACCESS)	2.4
SAFETY DISTANCE	1.4
MEWP DESIGN CLEARANCE FOR SAFETY (VERTICAL) D _{s2}	5.8
MEWP DESIGN CLEARANCE FOR SAFETY (HORIZONTAL) D _{sh2}	4.9

ANNOTATION:

AUX TX	AUXILIARY TRANSFORMER
CB	CIRCUIT BREAKER
CSE	CABLE SEALING END
CVT	CAPACITIVE VOLTAGE TRANSFORMER
D/S	DISCONNECTOR
PI	POST INSULATOR
SA	SURGE ARRESTER
TX	TRANSFORMER

TO BE VIEWED IN CONJUNCTION WITH LAYOUT DRAWING OP-PRO918-LAY021.

THE PROPOSED SUBSTATION LAYOUT IS BASED ON THE ASSUMPTION THAT THERE ARE NO SITE RESTRICTIONS.

THE PROPOSED BUSBAR SIZE IS 90mm x 6mm AL CONDUCTOR (2000A RATING). THE BUSBAR SIZE SHALL BE CONFIRMED DURING DETAILED DESIGN.

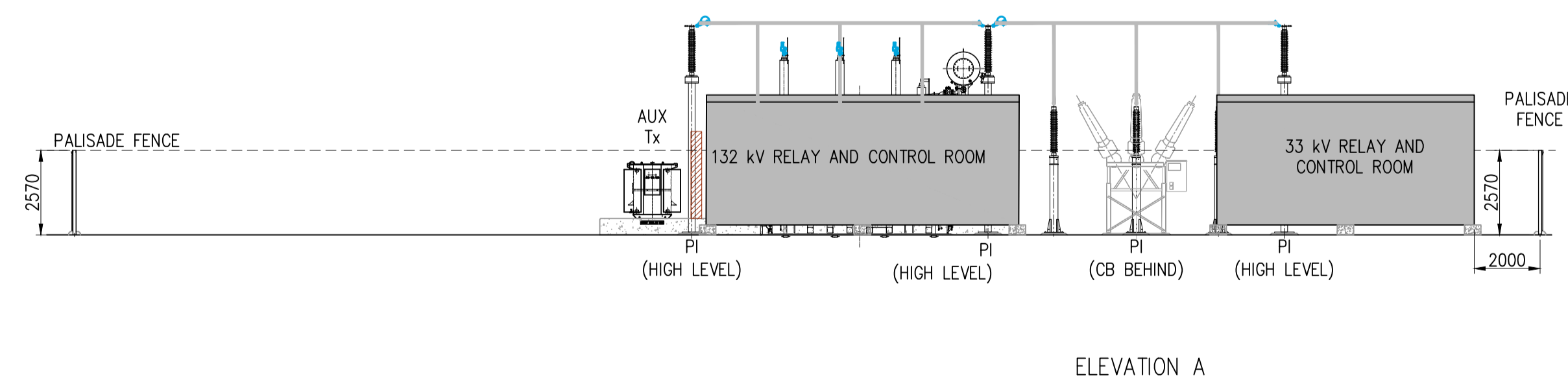
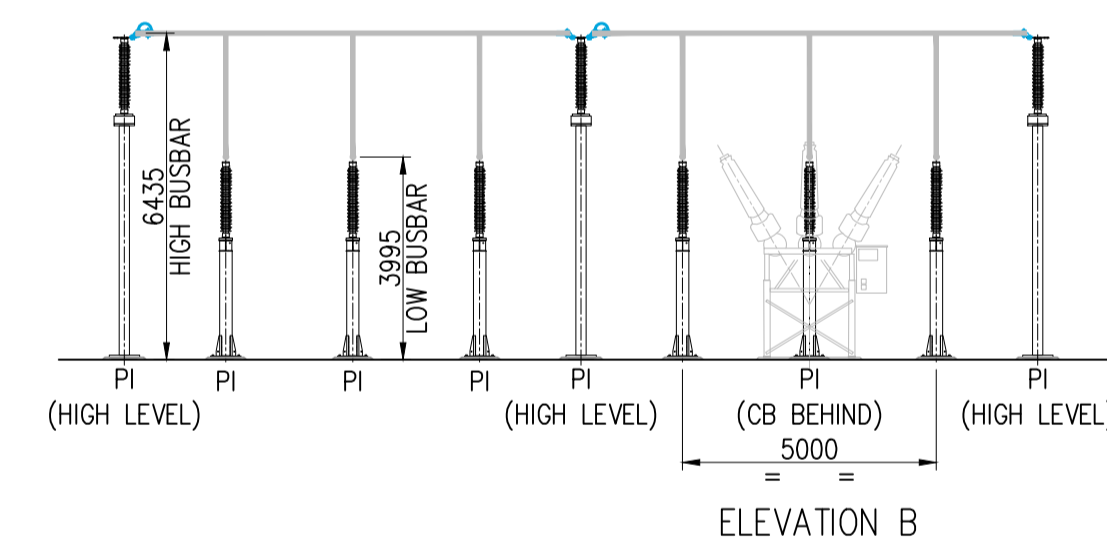
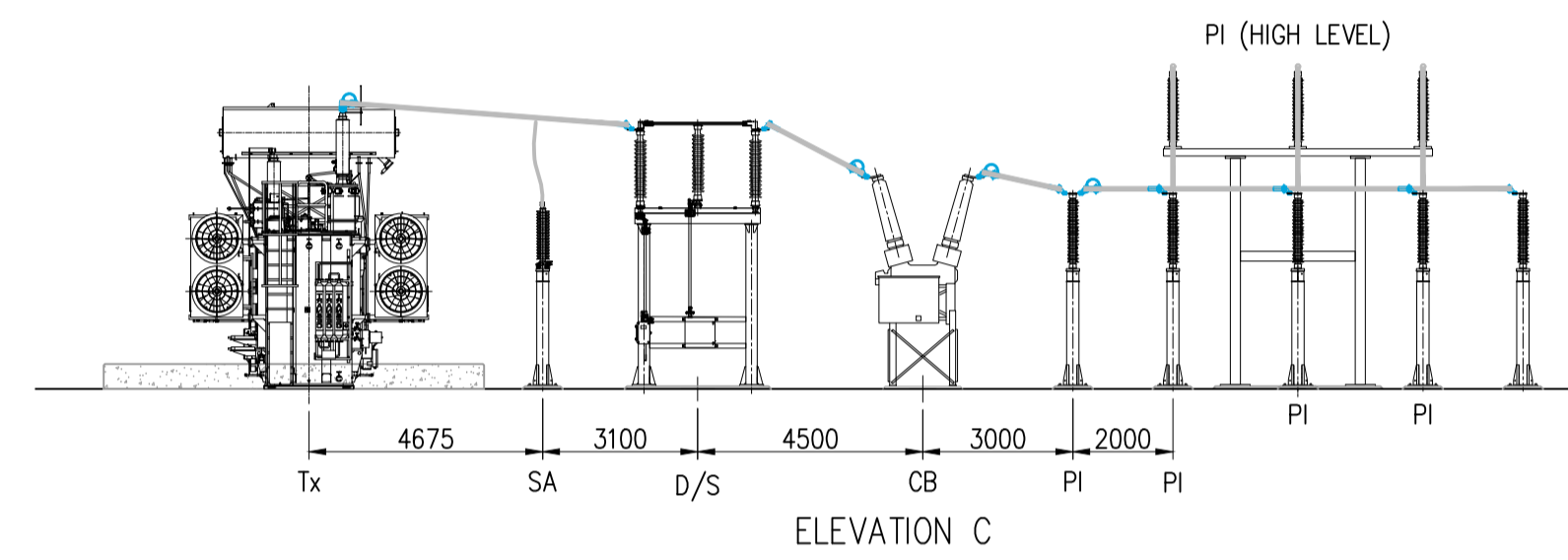
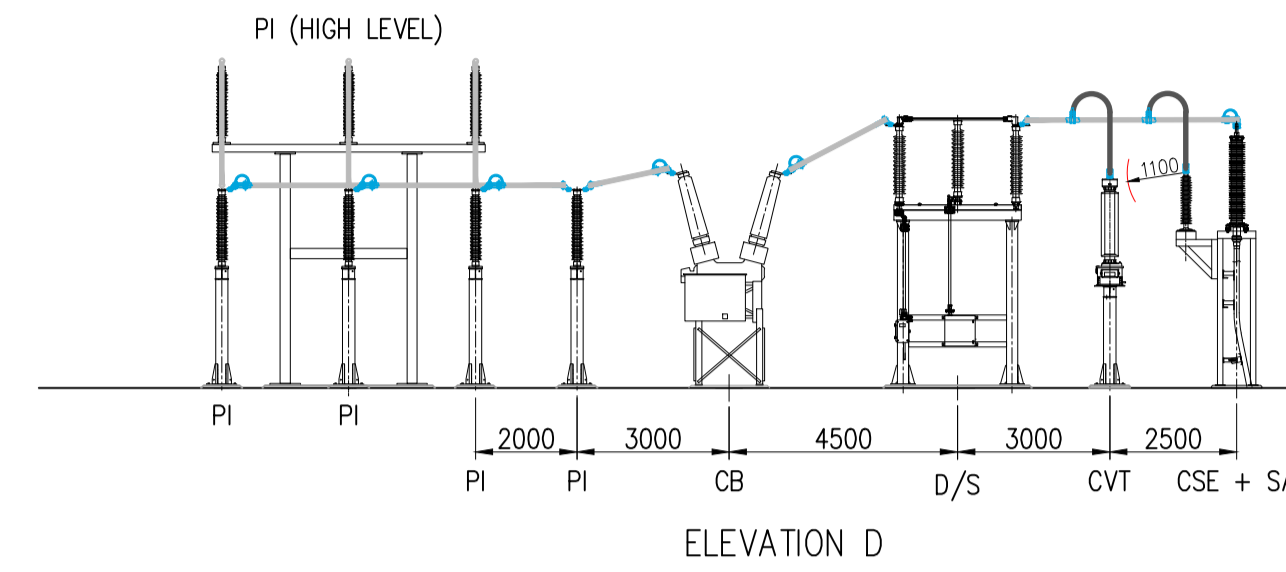

P1	11.07.22	PRELIMINARY	EC	EC	MG
----	----------	-------------	----	----	----

REV	DATE	DESCRIPTION	DRN	DES	REV & APP
-----	------	-------------	-----	-----	-----------

Do not scale from this drawing. All dimensions given in millimeters unless otherwise stated. Copyright owned by 'Omnia Projects'. This drawing may not be used or copied without written consent.

OMNIAProjects
The Catalyst, York Science Park, Baird Lane, Heslington, York YO10 5GA
email: office@omniaprojects.co.uk

Island GREEN POWER
www.islandgp.co.uk

WEST BURTON SOLAR PROJECT LIMITED

WEST BURTON 1 132/33kV SUBSTATION FOR SOLAR PARK
SIDE ELEVATIONS

PROJECT NAME
NATIONAL GRID WEST BURTON CONNECTION

CUSTOMER
ISLAND GREEN POWER

CUSTOMER DRAWING NUMBER	STATUS		
****	PRELIMINARY		
DRAWING NUMBER	SCALE	SIZE	REVISION
OP-PRO918-LAY022	1:150	A1	P1

PRELIMINARY
NOT FOR SITE USE

132kV MINIMUM ELECTRICAL CLEARANCES	
DESCRIPTION	DISTANCE (m)
PHASE TO PHASE CLEARANCE	1.4
PHASE TO EARTH CLEARANCE	1.1
DESIGN CLEARANCE FOR SAFETY (VERTICAL) D _{st}	3.8
DESIGN CLEARANCE FOR SAFETY (HORIZONTAL) D _{sh}	2.9
INSULATION HEIGHT (PEDESTRIAN ACCESS)	2.4
SAFETY DISTANCE	1.4
MEWP DESIGN CLEARANCE FOR SAFETY (VERTICAL) D _{sz}	5.8
MEWP DESIGN CLEARANCE FOR SAFETY (HORIZONTAL) D _{shz}	4.9

ABBREVIATION:

AUX TX	AUXILIARY TRANSFORMER
CB	CIRCUIT BREAKER
CSE	CABLE SEALING END
CVT	CAPACITIVE VOLTAGE TRANSFORMER
D/S	DISCONNECTOR
MK	MARSHALLING KIOSK
NER	NEUTRAL EARTHING RESISTOR
PI	POST INSULATOR
SA	SURGE ARRESTER
TX	TRANSFORMER

TO BE VIEWED IN CONJUNCTION WITH ELEVATIONS DRAWING OP-PRO918-LAY004.

THE PROPOSED SUBSTATION LAYOUT IS BASED ON ASSUMPTION THAT THERE IS NO SITE RESTRICTIONS.

THE PROPOSED BUSBAR SIZE IS 90mm x 6mm Al CONDUCTOR (2000A RATING). THE BUSBAR SIZED SHALL BE CONFIRMED DURING DETAILED DESIGN.

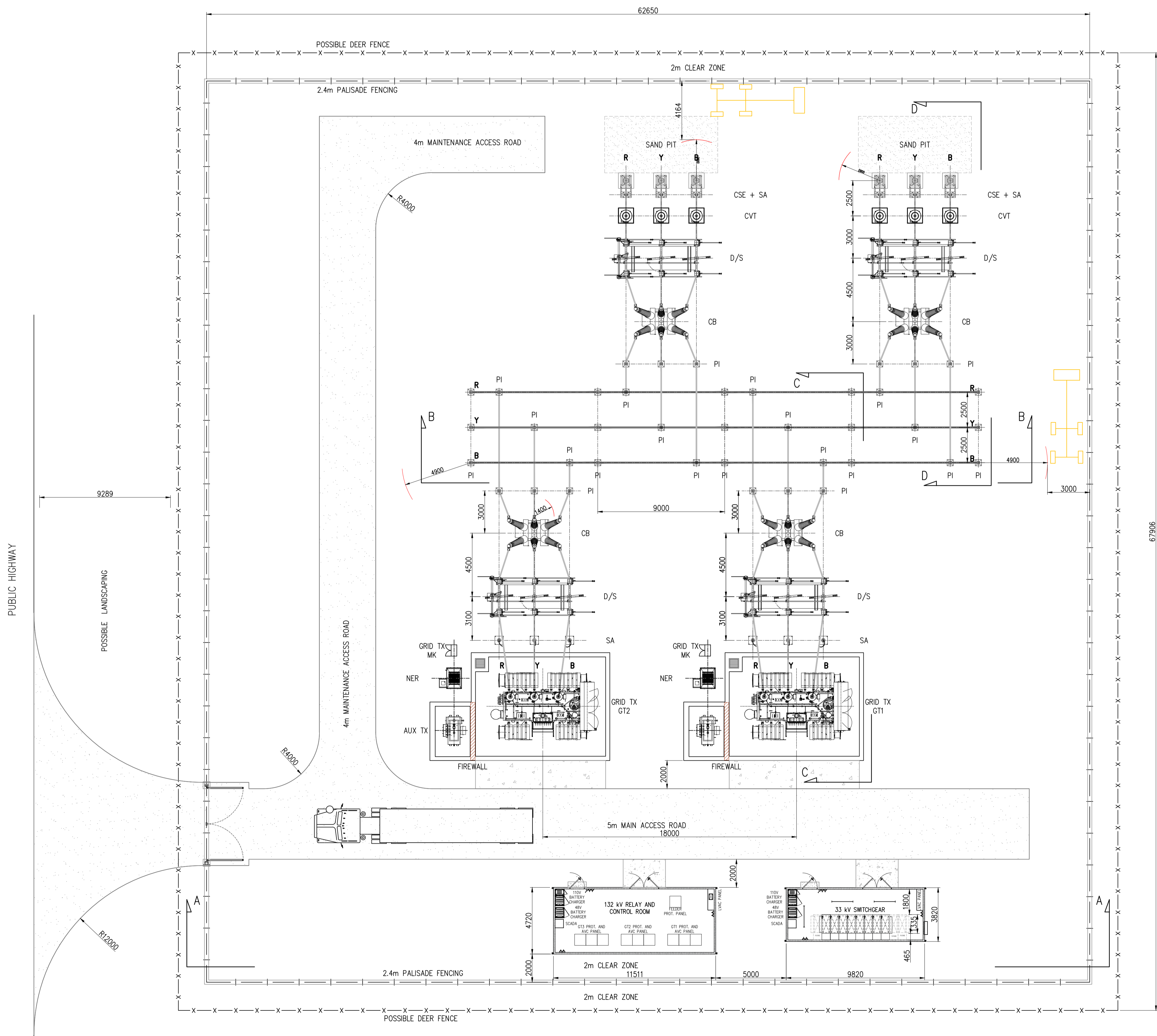

P4	19.07.22	ONE SGT REMOVED	EC	EC	MG
P3	11.07.22	ADDITIONAL FEEDER BAY ADDED BETWEEN GT2 AND GT3	EC	EC	MG
P2	27.08.21	SITE NAME CHANGED	DCP	EC	PD
P1	13.08.21	PRELIMINARY	DCP	EC	PD
REV	DATE	DESCRIPTION	DRN	DES	REV & APP

Do not scale from this drawing. All dimensions given in millimeters unless otherwise stated. Copyright owned by 'Omnia Projects'. This drawing may not be used or copied without written consent.

OMNIAProjects
 The Catalyst, York Science Park, Baird Lane, Heslington, York YO10 5GA
 email: office@omniaprojects.co.uk

Island GREEN POWER WEST BURTON SOLAR PROJECT LIMITED
 www.islandgp.co.uk

WEST BURTON 2 SOLAR PARK
 132/33kV SUBSTATION COMPOUND

PROJECT NAME
 NATIONAL GRID WEST BURTON CONNECTION
 CUSTOMER
 ISLAND GREEN POWER

PRELIMINARY		STATUS	
NOT FOR SITE USE		PRELIMINARY	
DRAWING NUMBER	SCALE	SIZE	REVISION
OP-PRO918-LAY003	1:150	A1	P4

132kV MINIMUM ELECTRICAL CLEARANCES	
DESCRIPTION	DISTANCE (m)
PHASE TO PHASE CLEARANCE	1.4
PHASE TO EARTH CLEARANCE	1.1
DESIGN CLEARANCE FOR SAFETY (VERTICAL) D _{st}	3.8
DESIGN CLEARANCE FOR SAFETY (HORIZONTAL) D _{sh}	2.9
INSULATION HEIGHT (PEDESTRIAN ACCESS)	2.4
SAFETY DISTANCE	1.4
MEWP DESIGN CLEARANCE FOR SAFETY (VERTICAL) D _{s2}	5.8
MEWP DESIGN CLEARANCE FOR SAFETY (HORIZONTAL) D _{sh2}	4.9

ANNOTATION:

AUX TX	AUXILIARY TRANSFORMER
CB	CIRCUIT BREAKER
CSE	CABLE SEALING END
CVT	CAPACITIVE VOLTAGE TRANSFORMER
D/S	DISCONNECTOR
PI	POST INSULATOR
SA	SURGE ARRESTER
TX	TRANSFORMER

TO BE VIEWED IN CONJUNCTION WITH LAYOUT DRAWING OP-PRO918-LAY003.

THE PROPOSED SUBSTATION LAYOUT IS BASED ON THE ASSUMPTION THAT THERE ARE NO SITE RESTRICTIONS.

THE PROPOSED BUSBAR SIZE IS 90mm x 6mm AL CONDUCTOR (2000A RATING). THE BUSBAR SIZE SHALL BE CONFIRMED DURING DETAILED DESIGN.

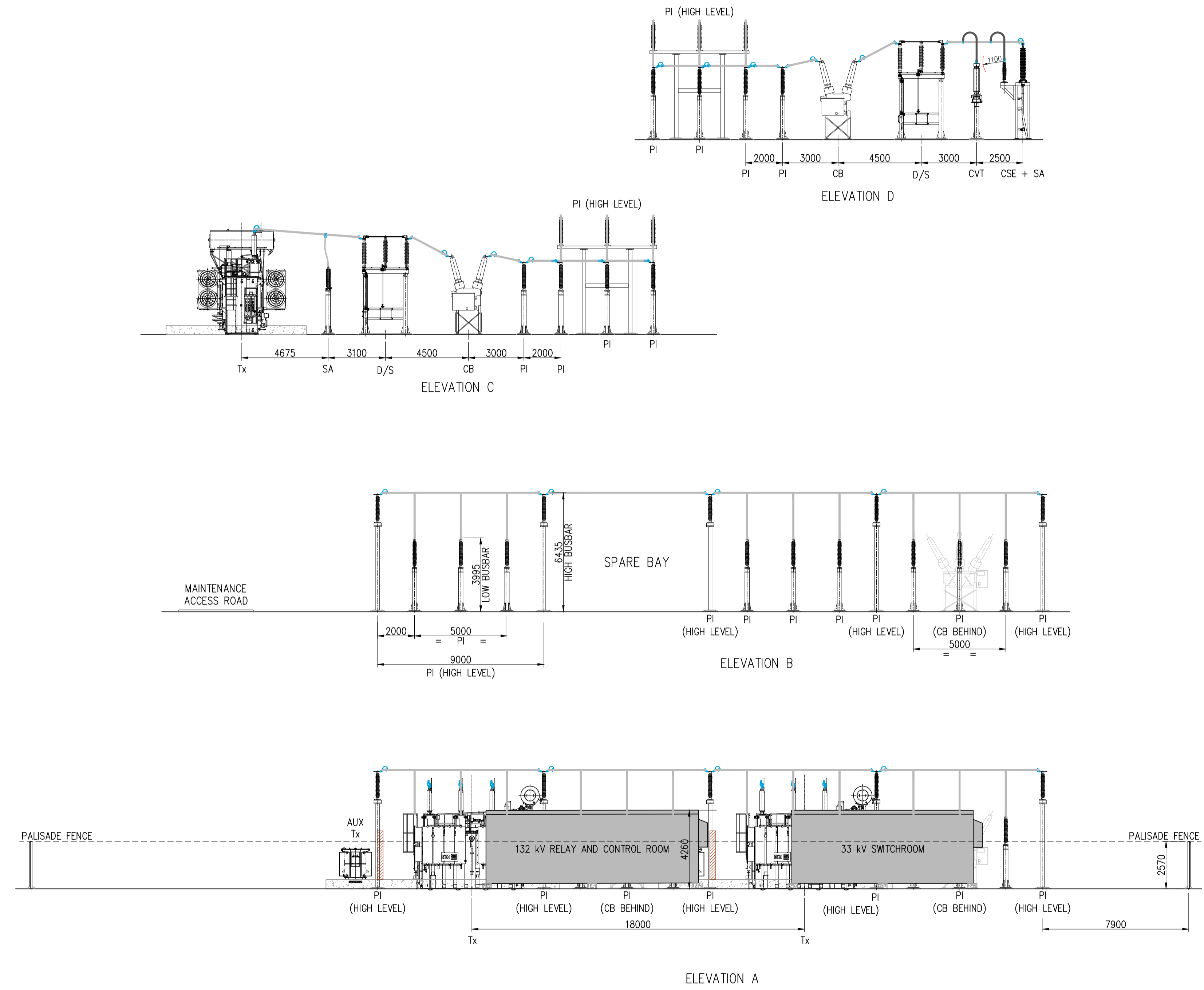

REV	DATE	DESCRIPTION	DRN	DES	REV & APP
P4	19.07.22	ONE SGT REMOVED	EC	EC	MG
P3	11.07.22	ADDITIONAL FEEDER BAY ADDED BETWEEN GT2 AND GT3	EC	EC	MG
P2	27.08.21	SITE NAME CHANGED	DCP	EC	PD
P1	13.08.21	PRELIMINARY	DCP	EC	PD

Do not scale from this drawing. All dimensions given in millimeters unless otherwise stated. Copyright owned by 'Omnia Projects'. This drawing may not be used or copied without written consent.



WEST BURTON 2 SOLAR PARK
132/33kV SUBSTATION SIDE ELEVATIONS

PROJECT NAME
NATIONAL GRID WEST BURTON CONNECTION
CUSTOMER
ISLAND GREEN POWER

PRELIMINARY NOT FOR SITE USE	CUSTOMER DRAWING NUMBER ****	STATUS PRELIMINARY
	DRAWING NUMBER OP-PRO918-LAY004	SCALE 1:150

400kV MINIMUM ELECTRICAL CLEARANCES	
DESCRIPTION	DISTANCE (m)
PHASE TO PHASE CLEARANCE	3.6
PHASE TO EARTH CLEARANCE	2.8
DESIGN CLEARANCE FOR SAFETY (VERTICAL) D ₉₀	5.5
DESIGN CLEARANCE FOR SAFETY (HORIZONTAL) D ₉₀	4.6
INSULATION HEIGHT (PEDESTRIAN ACCESS)	2.4
SAFETY DISTANCE	3.1
MEWP DESIGN CLEARANCE FOR SAFETY (VERTICAL) D ₉₀	7.5
MEWP DESIGN CLEARANCE FOR SAFETY (HORIZONTAL) D ₉₀	6.6

132kV MINIMUM ELECTRICAL CLEARANCES	
DESCRIPTION	DISTANCE (m)
PHASE TO PHASE CLEARANCE	1.4
PHASE TO EARTH CLEARANCE	1.1
DESIGN CLEARANCE FOR SAFETY (VERTICAL) D ₉₀	3.8
DESIGN CLEARANCE FOR SAFETY (HORIZONTAL) D ₉₀	2.9
INSULATION HEIGHT (PEDESTRIAN ACCESS)	2.4
SAFETY DISTANCE	1.4
MEWP DESIGN CLEARANCE FOR SAFETY (VERTICAL) D ₉₀	5.8
MEWP DESIGN CLEARANCE FOR SAFETY (HORIZONTAL) D ₉₀	4.9

- ABBREVIATION:
- AUX TX AUXILIARY TRANSFORMER
 - CB CIRCUIT BREAKER
 - CSE CABLE SEALING END
 - CVT CAPACITIVE VOLTAGE TRANSFORMER
 - D/S DISCONNECTOR
 - E/S EARTH SWITCH
 - MK MARSHALLING KIOSK
 - PA PANTOGRAPH
 - PI POST INSULATOR
 - SA SURGE ARRESTER
 - TX TRANSFORMER

TO BE VIEWED IN CONJUNCTION WITH ELEVATIONS DRAWING OP-PR0918-LAY026.

THE PROPOSED SUBSTATION LAYOUT IS BASED ON ASSUMPTION THAT THERE ARE NO SITE RESTRICTIONS.

THE PROPOSED 400kV MAIN BUSBAR SIZE IS 300mm x 8mm AL CONDUCTOR. THE PROPOSED BAY BUSBAR SIZE IS 160mm x 7mm. THE BUSBAR SIZE SHALL BE CONFIRMED DURING DETAILED DESIGN.

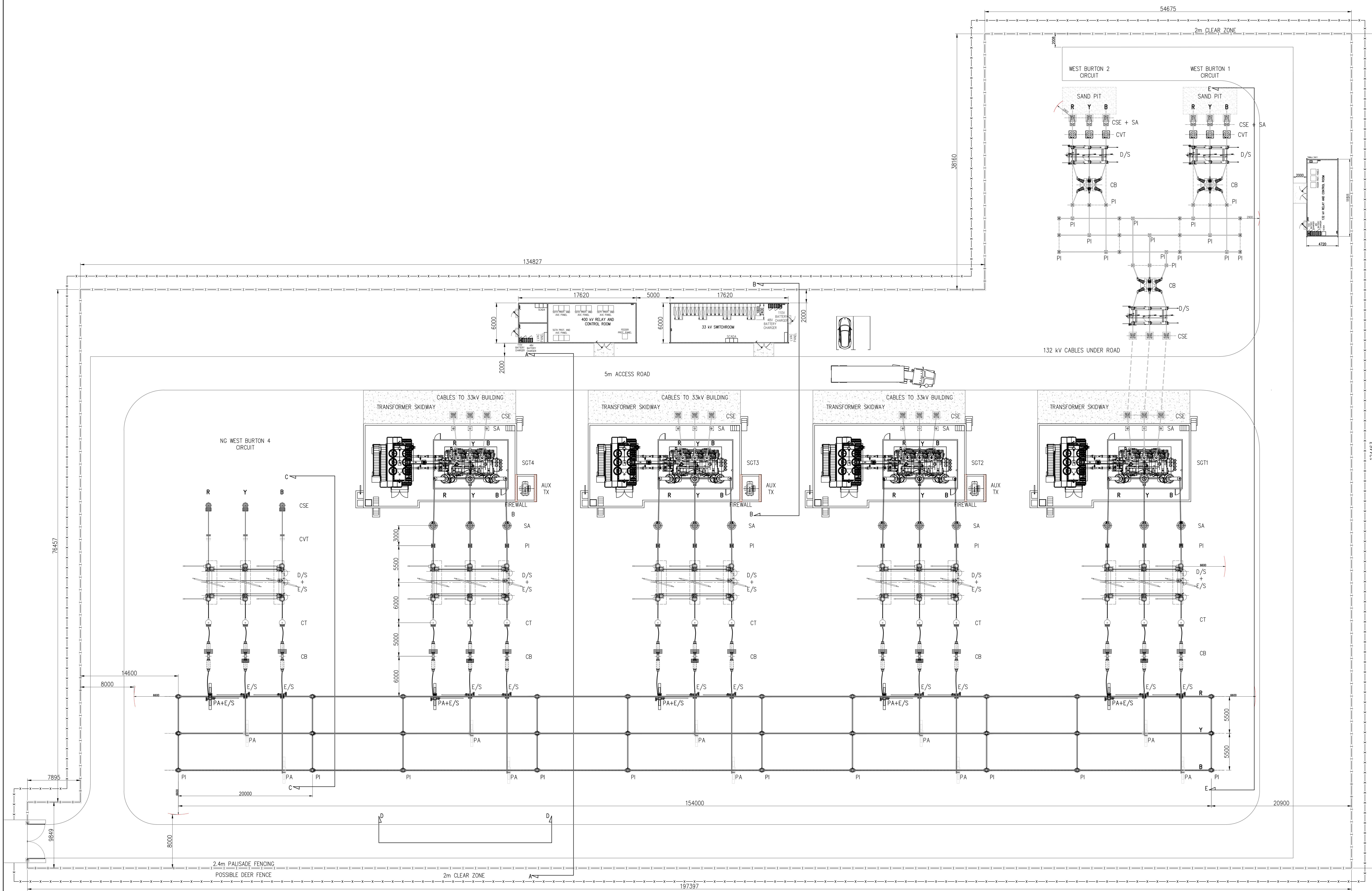

REV	DATE	DESCRIPTION	DRN	DES	REV A
P3	15.02.23	ADDITIONAL FEEDERS TO WEST BURTON 2 REMOVED	EC	EC	MG
P2	09.02.23	AMENDED AS PER LATEST SLD	EC	EC	MG
P1	28.09.22	PRELIMINARY	EC	EC	MG

Do not scale from this drawing. All dimensions given in millimeters unless otherwise stated. Copyright owned by Omnia Projects. This drawing may not be used or copied without written consent.

OMNIAProjects
The Catalyst, York Science Park, Bold Lane, Heslington, York YO10 5GA
email: office@omniaprojects.co.uk

Island GREEN POWER WEST BURTON SOLAR PROJECT LIMITED
www.islandgp.co.uk

WEST BURTON 3 SOLAR PARK
400/33kV SUBSTATION COMPOUND (AIS OPTION)

PROJECT NAME: NATIONAL GRID WEST BURTON CONNECTION
CUSTOMER: ISLAND GREEN POWER

PRELIMINARY
NOT FOR SITE USE

CUSTOMER DRAWING NUMBER: OP-PR0918-LAY025
STATUS: PRELIMINARY
SCALE: 1:200
DATE: A0
REVISION: P3

132kV MINIMUM ELECTRICAL CLEARANCES	
DESCRIPTION	DISTANCE (m)
PHASE TO PHASE CLEARANCE	1.4
PHASE TO EARTH CLEARANCE	1.1
DESIGN CLEARANCE FOR SAFETY (VERTICAL) D _{st}	3.8
DESIGN CLEARANCE FOR SAFETY (HORIZONTAL) D _{sh}	2.9
INSULATION HEIGHT (PEDESTRIAN ACCESS)	2.4
SAFETY DISTANCE	1.4
MEWP DESIGN CLEARANCE FOR SAFETY (VERTICAL) D _{sz}	5.8
MEWP DESIGN CLEARANCE FOR SAFETY (HORIZONTAL) D _{sz2}	4.9

400kV MINIMUM ELECTRICAL CLEARANCES	
DESCRIPTION	DISTANCE (m)
PHASE TO PHASE CLEARANCE	3.6
PHASE TO EARTH CLEARANCE	2.8
DESIGN CLEARANCE FOR SAFETY (VERTICAL) D _{st}	5.5
DESIGN CLEARANCE FOR SAFETY (HORIZONTAL) D _{sh}	4.6
INSULATION HEIGHT (PEDESTRIAN ACCESS)	2.4
SAFETY DISTANCE	3.1
MEWP DESIGN CLEARANCE FOR SAFETY (VERTICAL) D _{sz}	7.5
MEWP DESIGN CLEARANCE FOR SAFETY (HORIZONTAL) D _{sz2}	6.6

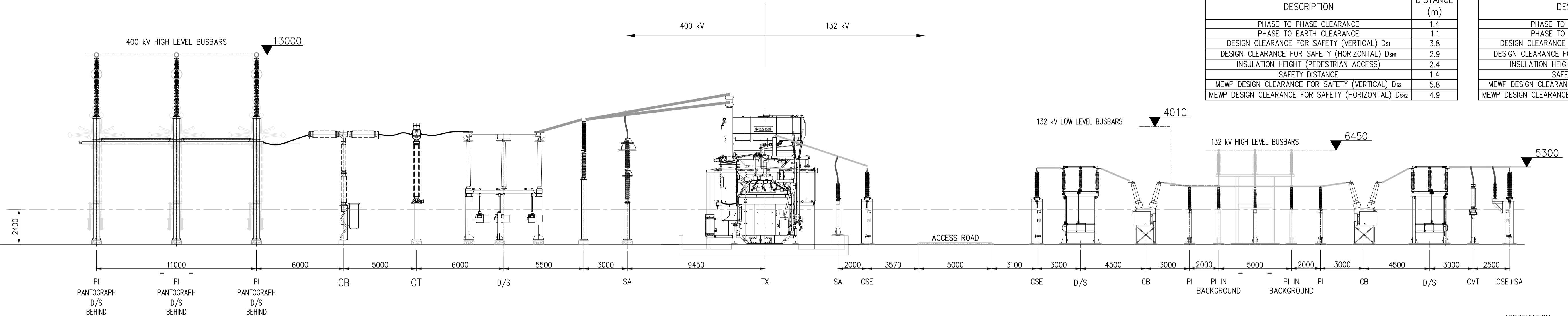

ELEVATION E
SCALE 1:150

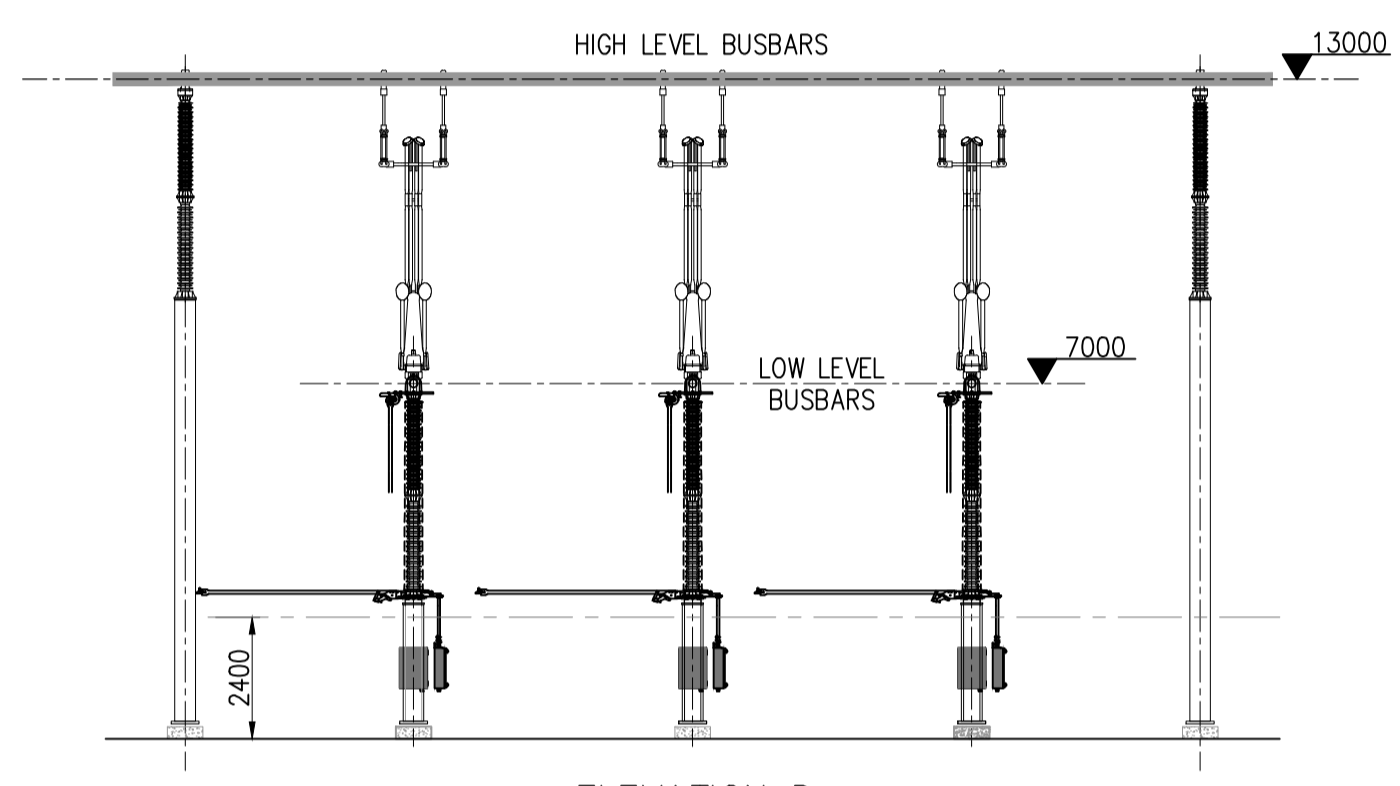

ELEVATION D
SCALE 1:150

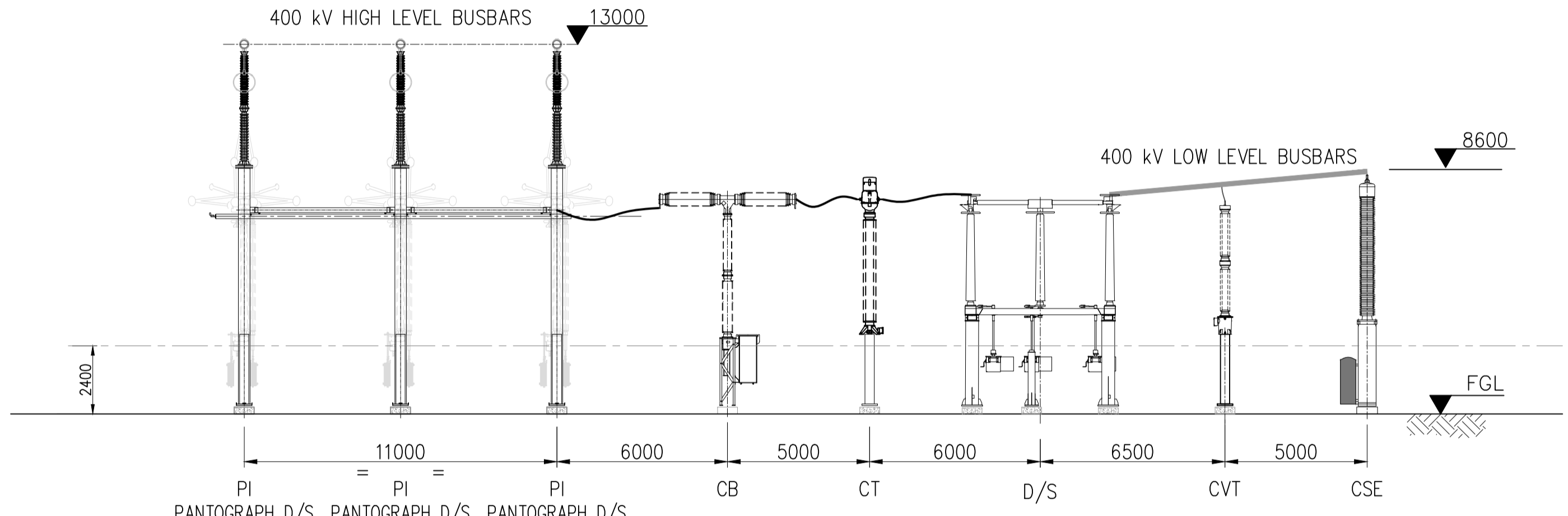

ELEVATION C
SCALE 1:150

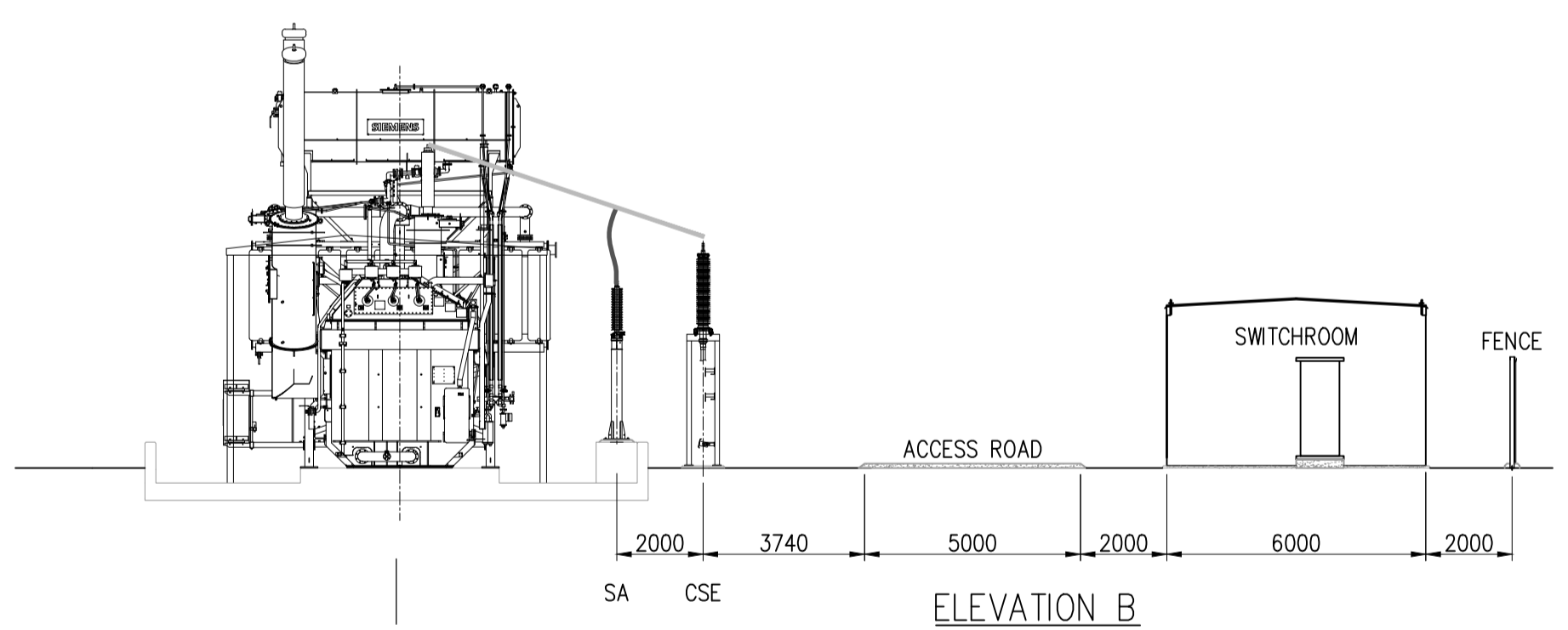

ELEVATION B
SCALE 1:150

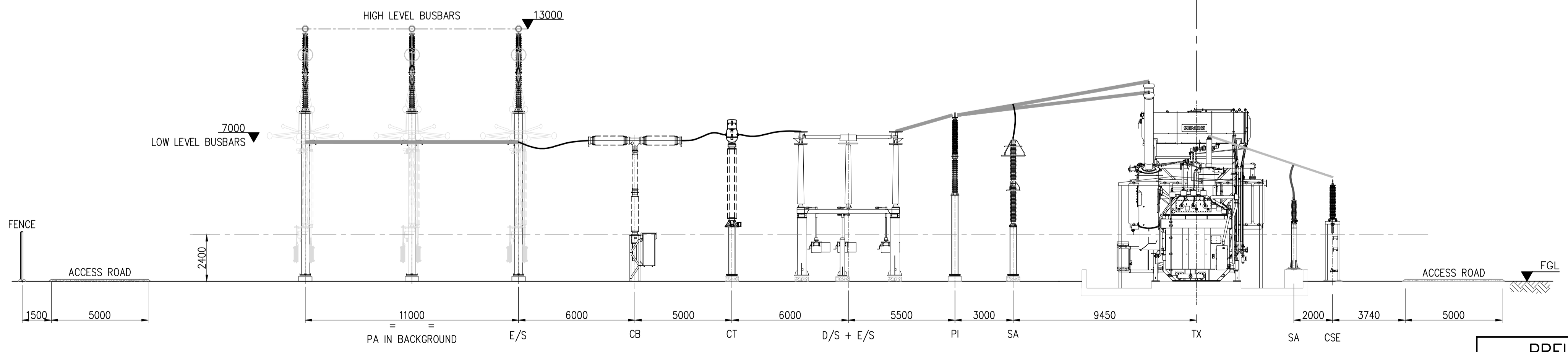

ELEVATION A
SCALE 1:150

- ABBREVIATION:
- AUX TX AUXILIARY TRANSFORMER
 - CB CIRCUIT BREAKER
 - CSE CABLE SEALING END
 - CVT CAPACITIVE VOLTAGE TRANSFORMER
 - D/S DISCONNECTOR
 - E/S EARTH SWITCH
 - MK MARSHALLING KIOSK
 - PA PANTOGRAPH
 - PI POST INSULATOR
 - SA SURGE ARRESTER
 - TX TRANSFORMER

TO BE VIEWED IN CONJUNCTION WITH SUBSTATION LAYOUT DRAWING OP-PRO918-LAY025.

THE PROPOSED SUBSTATION LAYOUT IS BASED ON ASSUMPTION THAT THERE ARE NO SITE RESTRICTIONS.

THE PROPOSED 400kV MAIN BUSBAR SIZE IS 300mm x 8mm AL CONDUCTOR. THE PROPOSED BAY BUSBAR SIZE IS 160mm x 7mm. THE BUSBAR SIZE SHALL BE CONFIRMED DURING DETAILED DESIGN.

P1	26.09.22	PRELIMINARY	EC	EC	MG
REV	DATE	DESCRIPTION	DRN	DES	REV & APP

Do not scale from this drawing. All dimensions given in millimeters unless otherwise stated. Copyright owned by 'Omnia Projects'. This drawing may not be used or copied without written consent.



WEST BURTON 3 SOLAR PARK
400/33kV SUBSTATION COMPOUND
(AIS OPTION)

PROJECT NAME
NATIONAL GRID WEST BURTON CONNECTION
CUSTOMER
ISLAND GREEN POWER

CUSTOMER DRAWING NUMBER ****	STATUS PRELIMINARY
DRAWING NUMBER OP-PRO918-LAY026	SCALE 1:150
SIZE A1	REVISION P1

PRELIMINARY
NOT FOR SITE USE

TRENCH SECTIONS FOR 132kV CABLES

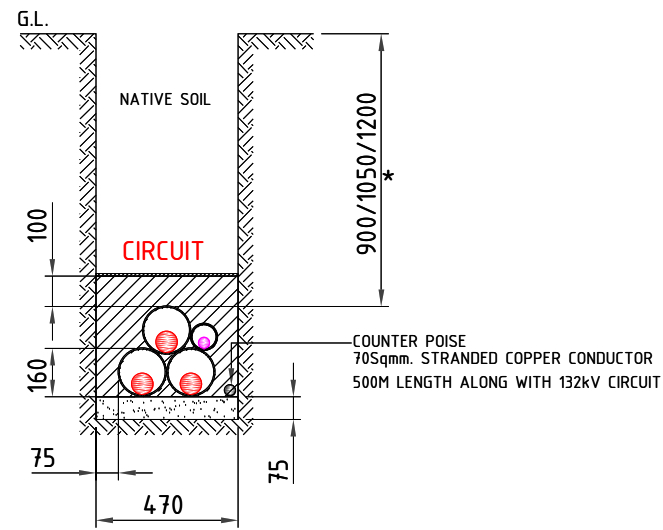

TRENCH SECTIONS FOR 132kV CABLES

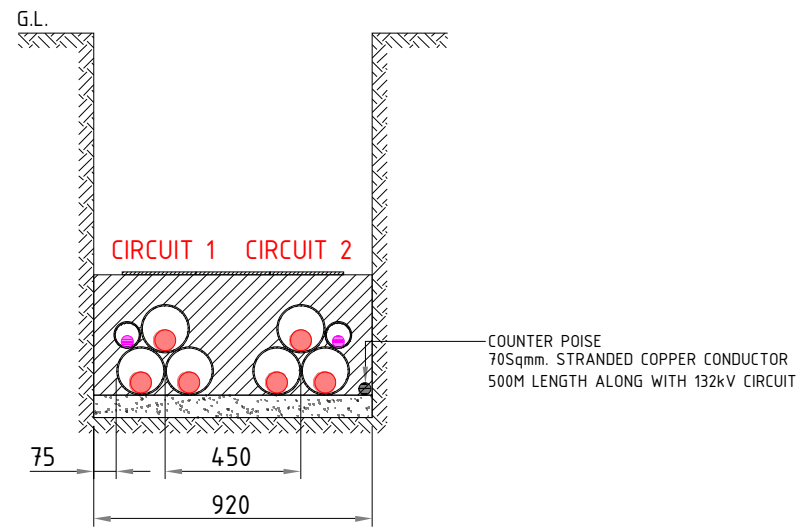

SOLIDLY OR CROSS BONDING SYSTEM TO BE USED

TYPE A

- STOKBORD (1000x244x9mm)
- G.L. - GROUND LEVEL**
- 132KV CABLE
- FIBRE CABLE

BEDDING A CEMENT BOUND SAND BED COMPLYING WITH THE REQUIREMENTS OF ENA TS 97-01 SHALL BE INSTALLED, EXCEPT WHERE CABLE RATING CALCULATIONS PROVE THAT STABILISED MATERIAL IS NOT REQUIRED. ALL BEDDING LAYERS SHALL BE COMPACTED TO A DEPTH OF 75mm.

BLINDING CABLES SHALL BE BLINDED WITH CEMENT BOUND SAND COMPLYING WITH THE REQUIREMENTS OF ENA TS 97-01, EXCEPT WHERE CABLE RATING CALCULATIONS PROVE THAT A STABILISED MATERIAL IS NOT REQUIRED, TO A COMPACTED DEPTH OF 100mm ABOVE THE CABLE.

INSTALLATION DEPTH DEPENDANT ON LOCATION:
 900mm FOOTWAYS/GRASS VERGES/PRIVATE PROPERTY & CARRIAGEWAYS (INCLUDING ROAD CROSSINGS)
 ★ 1050mm NORMAL AGRICULTURAL LAND
 1200mm AGRICULTURAL LAND SUBJECT TO DEEP PLOUGH

TRENCH SECTIONS FOR 400kV CABLES

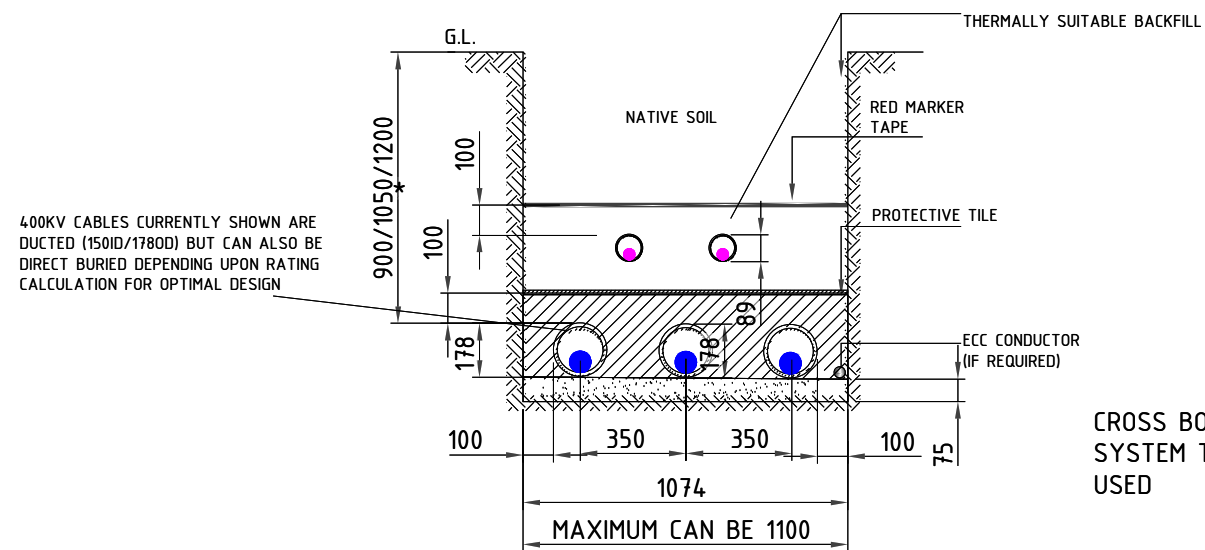

CROSS BONDING SYSTEM TO BE USED

TYPE A

- STOKBORD (1000x244x9mm)
- G.L. - GROUND LEVEL**
- 400KV CABLE
- FIBRE CABLE

BEDDING A CEMENT BOUND SAND BED COMPLYING WITH THE REQUIREMENTS OF ENA TS 97-01 SHALL BE INSTALLED, EXCEPT WHERE CABLE RATING CALCULATIONS PROVE THAT STABILISED MATERIAL IS NOT REQUIRED. ALL BEDDING LAYERS SHALL BE COMPACTED TO A DEPTH OF 75mm.

BLINDING CABLES SHALL BE BLINDED WITH CEMENT BOUND SAND COMPLYING WITH THE REQUIREMENTS OF ENA TS 97-01, EXCEPT WHERE CABLE RATING CALCULATIONS PROVE THAT A STABILISED MATERIAL IS NOT REQUIRED, TO A COMPACTED DEPTH OF 100mm ABOVE THE CABLE.

INSTALLATION DEPTH DEPENDANT ON LOCATION:
 900mm FOOTWAYS/GRASS VERGES/PRIVATE PROPERTY & CARRIAGEWAYS (INCLUDING ROAD CROSSINGS)
 ★ 1050mm NORMAL AGRICULTURAL LAND
 1200mm AGRICULTURAL LAND SUBJECT TO DEEP PLOUGH

General Legend:



Project:	West Burton Solar Project
Project Location:	Land near Gainsborough, Lincolnshire, United Kingdom
Ownership:	West Burton Solar Project Limited
Document Title:	Cable Trench Cross Section
Sheet Format:	A3 420 x 297
Scale:	1:25
Document Version:	v.1 16/02/2023 M.N.
Company:	Island Green Power Island Green Power UK Limited Unit 20.2, Coda Studios 189 Munster Road, London SW6 6AW

HDD TRENCH SECTION FOR 132kV, 400kV CABLES & FIBRE CABLES

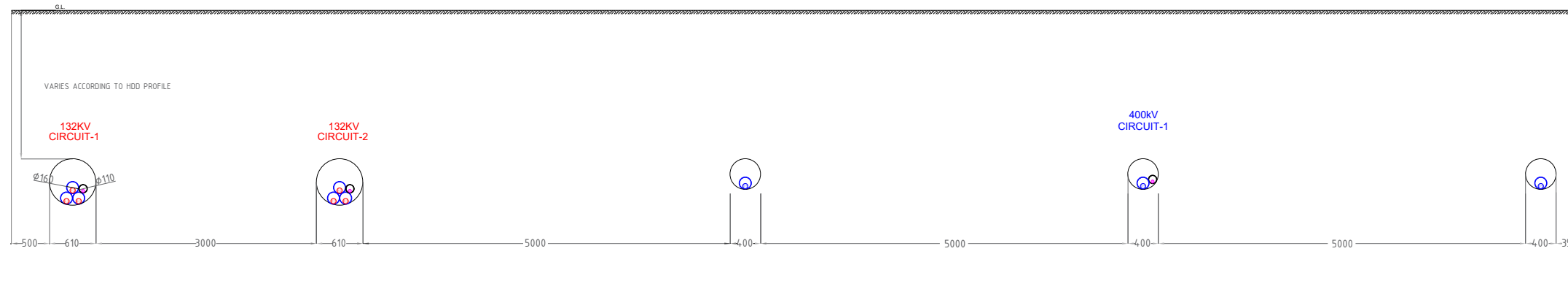

- G.L. - GROUND LEVEL | ● 132kV CABLE SINGLE CORE AL OR COPPER (TBC) | ● 400kV CABLE SINGLE CORE AL OR COPPER (TBC) | ● FIBRE CABLE | — 1 X 110MM SDR11 BLACK ELECTRIC DUCTING | — 3 X 160MM SDR11 BLACK ELECTRIC DUCTING

General Legend:

General Legend:	



Project:	West Burton Solar Project	
Project Location:	Land near Gainsborough, Lincolnshire, United Kingdom	
Ownership:	West Burton Solar Project Limited	
Document Title:	HDD Trench Section for 132kV, 400kV and Fibre Cables	
Sheet Format:	A3 "420 x 297"	Scale: 1:75
Document Version:	v.1	14/02/2023
Document Author:	M.N.	
Document Reviewer:		
Company:	Island GREEN POWER	Island Green Power UK Limited Unit 20.2, Coda Studios 189 Munster Road, London SW6 6AW

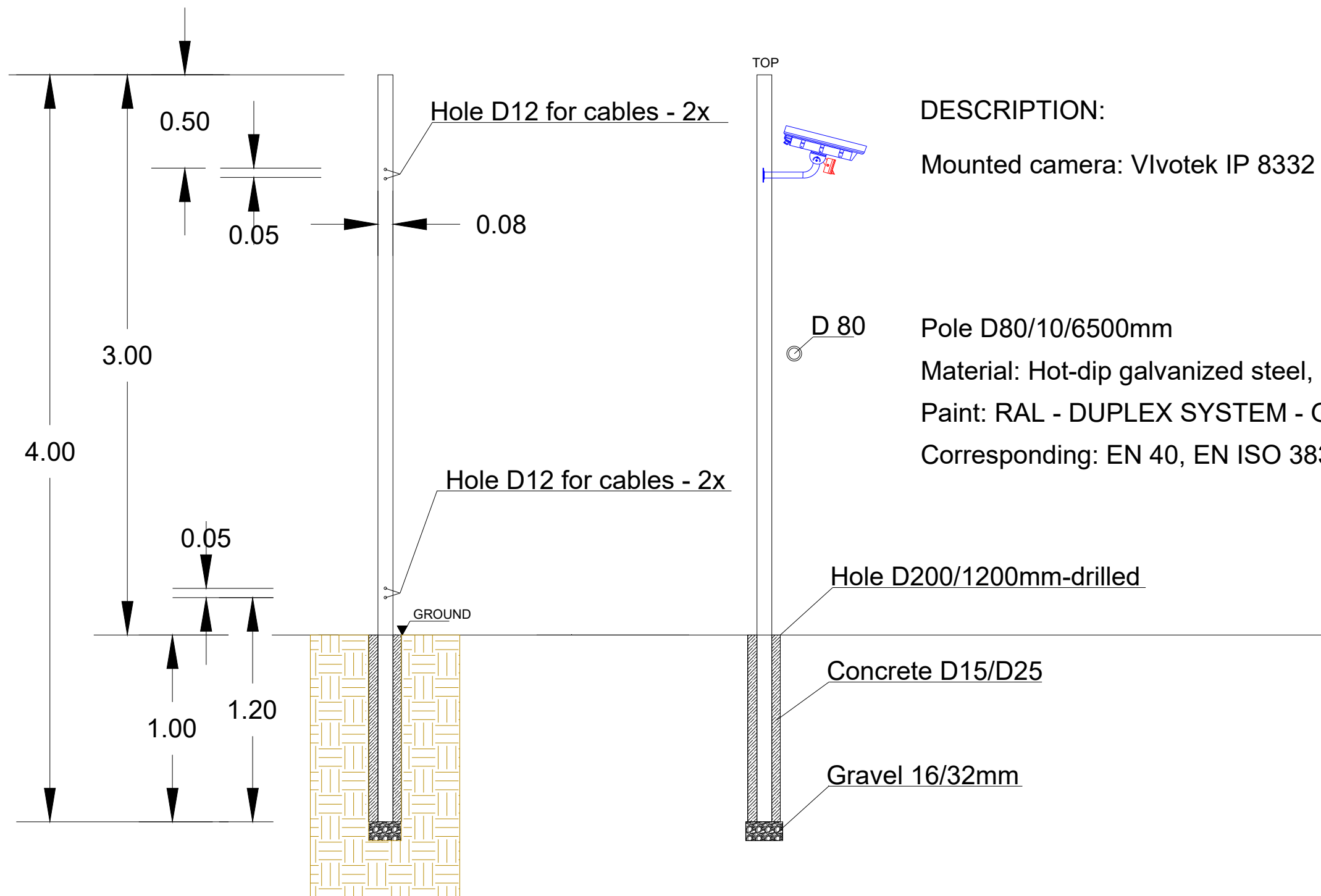

DESCRIPTION:

Mounted camera: Vivotek IP 8332 2Mpx, with IR light

Pole D80/10/6500mm

Material: Hot-dip galvanized steel, DIN EN ISO 1461

Paint: RAL - DUPLEX SYSTEM - GREEN

Corresponding: EN 40, EN ISO 3834, EN ISO 9001.2001

Distance between the poles: 50 meters (max.)

General Legend:	

Project:	West Burton Solar Project									
Project Location:	Land near Gainsborough, Lincolnshire, United Kingdom									
Ownership:	West Burton Solar Project Limited									
Document Title:	Indicative CCTV									
Sheet format:	A3 "420 x 297"	Scale: 1:25								
Document amendments:	<table border="1"> <thead> <tr> <th>v.</th> <th>Date</th> <th>M.N.</th> <th>Comments</th> </tr> </thead> <tbody> <tr> <td>v.1</td> <td>09/01/2023</td> <td>M.N.</td> <td></td> </tr> </tbody> </table>	v.	Date	M.N.	Comments	v.1	09/01/2023	M.N.		
v.	Date	M.N.	Comments							
v.1	09/01/2023	M.N.								
Company:	 Island Green Power UK Limited Unit 20.2, Coda Studios 189 Munster Road, London SW6 6AW									

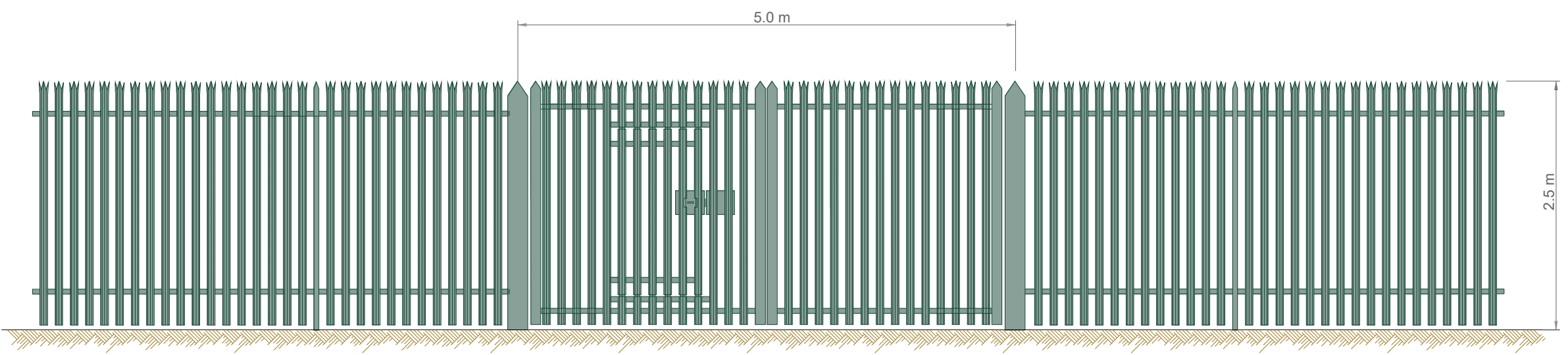

General Legend:

Project: West Burton Solar Project

Project Location: Land near Gainsborough, Lincolnshire, United Kingdom

Ownership: West Burton Solar Project Limited

Document Title: Substation and Energy Storage - Fence and Gate Elevations

Sheet format: A3 "420 x 297"

Document amendments	v.1	10/01/2023	M.N.	Comments

Scale: 1:50

Company: Island GREEN POWER

Island Green Power UK Limited
Unit 20.2, Coda Studios
189 Munster Road, London SW6 6AW

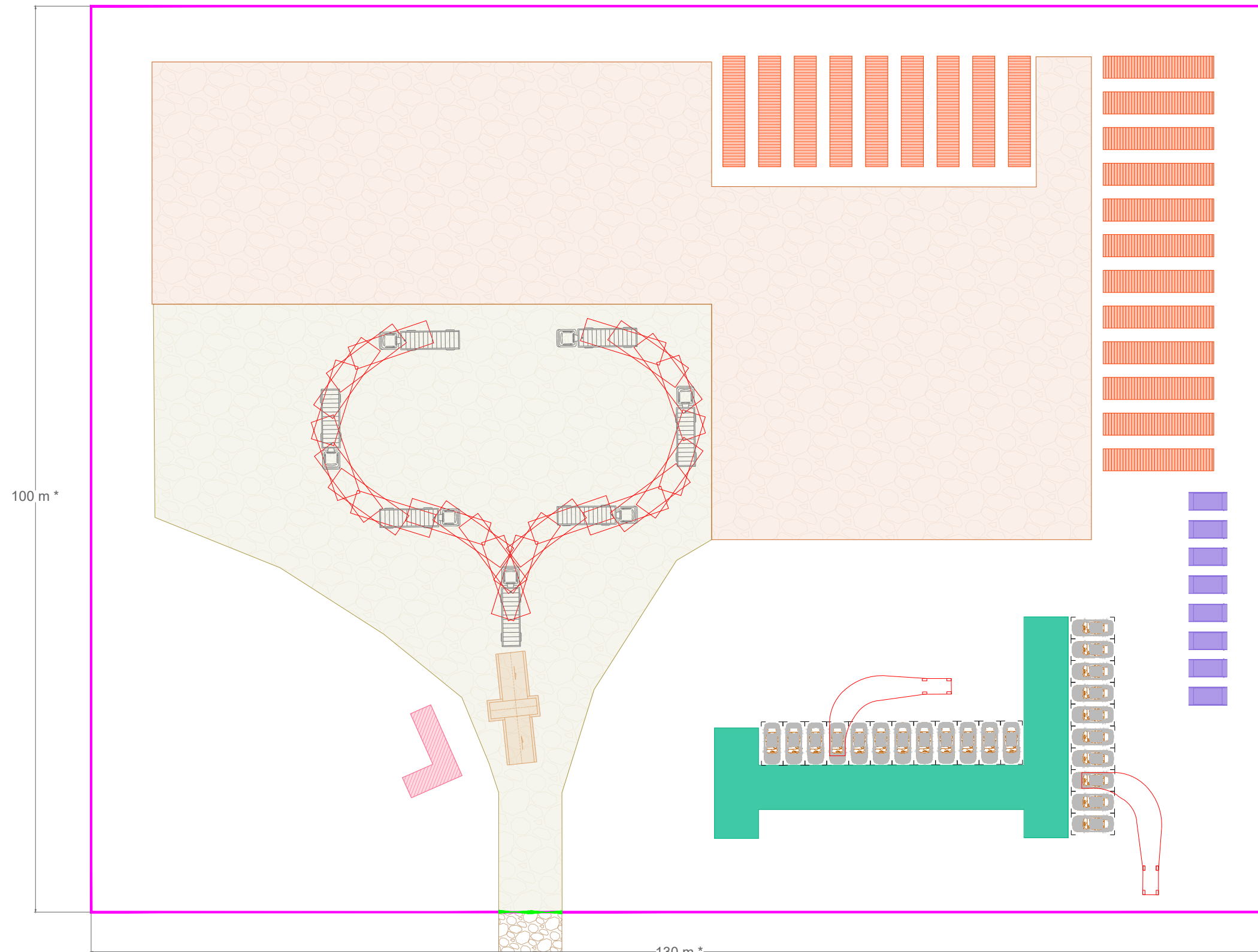

* Dimensions are indicative only

General Legend:	
	Construction Compound Boundary
	Gates
	Reception Area
	Turning Area for Delivery Vehicles
	Laydown Area
	Office and Welfare Unit
	Skip / Water Area
	Storage Containers
	Vehicle Wheel Washers
	Vehicle Swept Path
	Parking Area
	Temporary Track

Project:	West Burton Solar Project
Project Location:	Land near Gainsborough, Lincolnshire, United Kingdom
Ownership:	West Burton Solar Project Limited
Document Title:	Temporary Construction and Decommissioning Laydown Area
Sheet format:	A3 '420 x 297'
Scale:	1:500
Revision:	v.1 31/01/2023 M.N.
Comments:	
Company:	Island Green Power UK Limited Unit 20 Z, Coda Studios 189 Munster Road, London SW6 6AW

